

REFERENCE

SPEC. No. ED-04Q051B
ISSUE June 20, 2007

SHARP

OPTO-ANALOG DEVICES DIVISION
ELECTRONIC COMPONENTS GROUP
SHARP CORPORATION

SPECIFICATION

DEVICE SPECIFICATION FOR

VOLTAGE REGULATOR

MODEL No.

PQ1CG3032FZH

Specified for _____

Enclosed please find copies of the Specifications which consists of 15 pages including cover.
This specification sheets and attached sheets shall be both side copy.
After confirmation of the contents, please be sure to send back copies of the Specifications
with approving signature on each.

CUSTOMER'S APPROVAL

DATE _____

BY _____

PRESENTED

DATE June 20, 2007

BY H. Imanaka

H. Imanaka,
Department General Manager of
Engineering Dept., II
Opto-Analog Devices Div.
ELECOM Group
SHARP CORPORATION

Product name : VOLTAGE REGULATOR

Model No. : PO1CG3032FZH

1. These specification sheets include materials protected under copyright of Sharp Corporation ("Sharp"). Please do not reproduce or cause anyone to reproduce them without Sharp's consent.
2. When using this product, please observe the absolute maximum ratings and the instructions for use outlined in these specification sheets, as well as the precautions mentioned below. Sharp assumes no responsibility for any damage resulting from use of the product which does not comply with the absolute maximum ratings and the instructions included in these specification sheets, and the precautions mentioned below.

(Precautions)

- (1) This product is designed for use in the following application areas ;

(• OA equipment • Audio visual equipment • Home appliances
 • Telecommunication equipment (Terminal) • Measuring equipment
 • Tooling machines • Computers

If the use of the product in the above application areas is for equipment listed in paragraphs (2) or (3), please be sure to observe the precautions given in those respective paragraphs.

- (2) Appropriate measures, such as fail-safe design and redundant design considering the safety design of the overall system and equipment, should be taken to ensure reliability and safety when this product is used for equipment which demands high reliability and safety in function and precision, such as ;

(• Transportation control and safety equipment (aircraft, train, automobile etc.)
 • Traffic signals • Gas leakage sensor breakers • Rescue and security equipment
 • Other safety equipment

- (3) Please do not use this product for equipment which require extremely high reliability and safety in function and precision, such as ;

(• Space equipment • Telecommunication equipment (for trunk lines)
 • Nuclear power control equipment • Medical equipment

- (4) Please contact and consult with a Sharp sales representative if there are any questions regarding interpretation of the above three paragraphs.

3. Please contact and consult with a Sharp sales representative for any questions about this product.

1. Application

This specification applies to the outline and characteristics of chopper type regulator, Model No. PQ1CG3032FZH.

Usage

The PQ1CG3032FZH is a step-down variable output type PWM method chopper type regulator (Input voltage range : 4.5 to 40V) with the built-in ON/OFF control function of output voltage, over current protection function, over heat protection function, and soft start circuit, and is low consumption current type at OFF-state (stand-by) and is suitable for large dropout voltage application between input and output, and polarity inversion application.

Block diagram Refer to the attached sheet, page 4.

2. Outline : Refer to the attached sheet, page 5.

3. Ratings and characteristics : Refer to the attached sheet, page 6, 7.

3.1 Absolute maximum ratings (Fig. 1) Pd-Ta rating (Typical value)

3.2 Electrical characteristics

3.3 Electrical characteristics measuring circuit

4. Reliability Refer to the attached sheet, Page 8.

5. Outgoing inspection Refer to the attached sheet, Page 8.

6. Supplement

6.1 Example of application : Refer to the attached sheet, Page 9.

6.2 This product is not designed as electromagnetic and ionized-particle radiation resistant.

6.3 ODS materials

This product shall not contain the following materials.

Also, the following materials shall not be used in the production process for this product.

Materials for ODS : CFCs, Halon, Carbon tetrachloride, 1.1.1-Trichloroethane (Methyl chloroform)

REFERENCE

6.4 Compliance with each regulation

6.4.1 The RoHS directive(2002/95/EC)

This product complies with the RoHS directive(2002/95/EC).

Object substances: mercury, lead (except for lead in high melting temperature type solders^{*1}), cadmium, hexavalent chromium, polybrominated biphenyls (PBB) and polybrominated diphenyl ethers (PBDE)

*1 : i.e. tin-lead solder alloys containing more than 85% lead

6.4.2 Content of six substances specified in Management Methods for Control of Pollution Caused by Electronic formation Products Regulation (Chinese : 电子信息产品污染控制管理办法).

Category	Toxic and hazardous substances					
	Lead (Pb)	Mercury (Hg)	Cadmium (Cd)	Hexavalent chromium (Cr ⁶⁺)	Polybrominated biphenyls (PBB)	Polybrominated diphenyl ethers (PBDE)
Voltage regulator	*	✓	✓	✓	✓	✓

✓ : indicates that the content of the toxic and hazardous substance in all the homogeneous materials of the part is below the concentration limit requirement as described in SJ/T 11363-2006 standard .

* : indicates that the content of the toxic and hazardous substance in at least one homogeneous material of the part exceeds the concentration limit requirement as described in SJ/T 11363-2006 standard.

Lead in high melting temperature type solders (i.e. tin-lead solder alloys containing more than 85% lead) (designated by “*” in the above table) are exempt from the RoHS directive (2002/95/EC) , because there is no effective way to eliminate or substitute them by present scientific technology.

6.5 Specified brominated flame retardants

Specified brominated flame retardants (PBB and PBDE) are not used in this device at all.

6.6 Packing specification : Refer to the attached sheet, Page 9.

7. Notes : Refer to the attached sheet, Page 11 to 14.

7.1 External connection

7.2 Thermal protection design

7.3 Adjustment of output voltage

7.4 ON/OFF control terminal in the following circuit

7.5 Mounting

7.6 Static electricity

7.7 Cleaning

7.8 Storage environment

7.9 Hand soldering

7.10 Input voltage to Oadj terminal

REFERENCE

PQ1CG3032FZH Block diagram

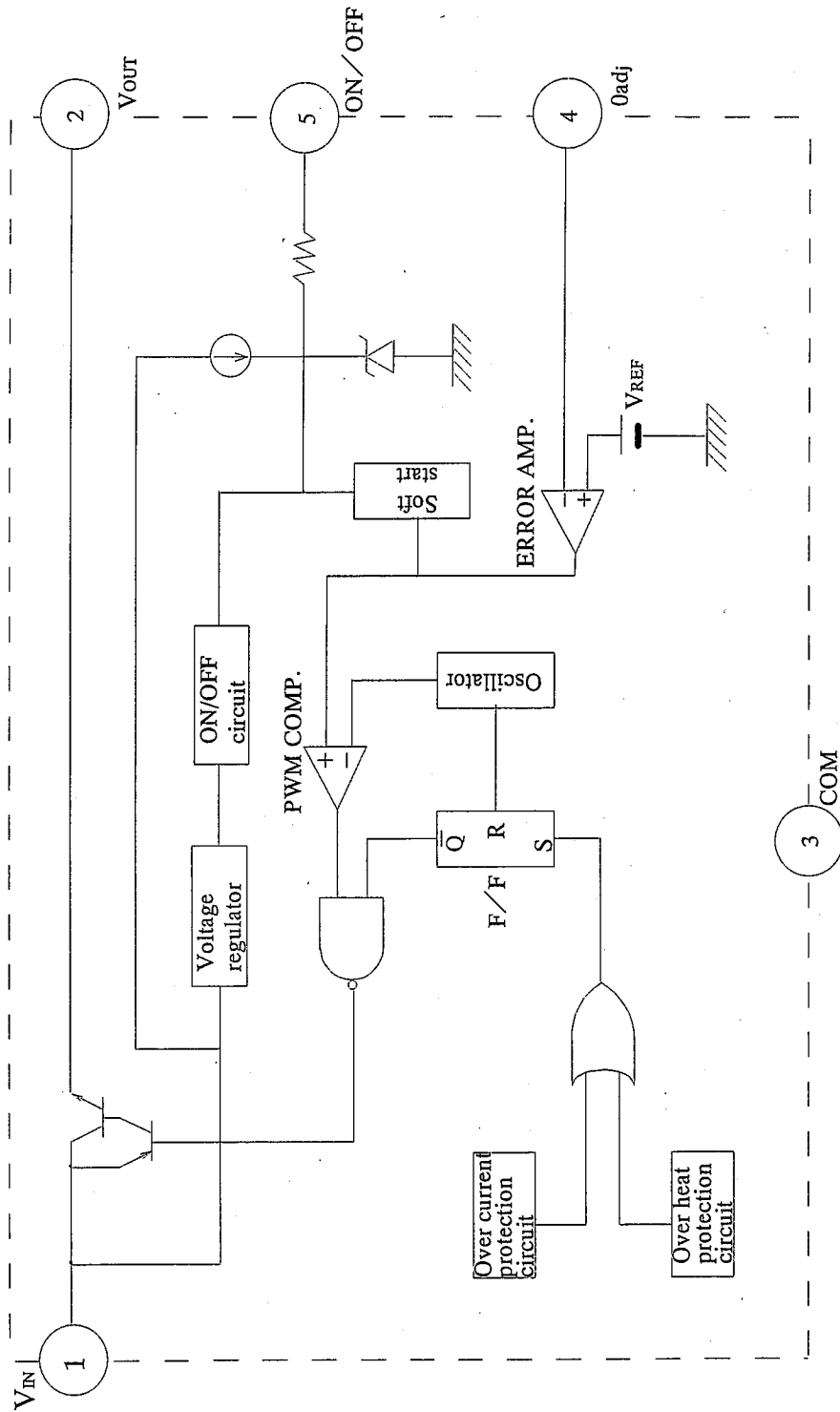

REFERENCE

2. Outline

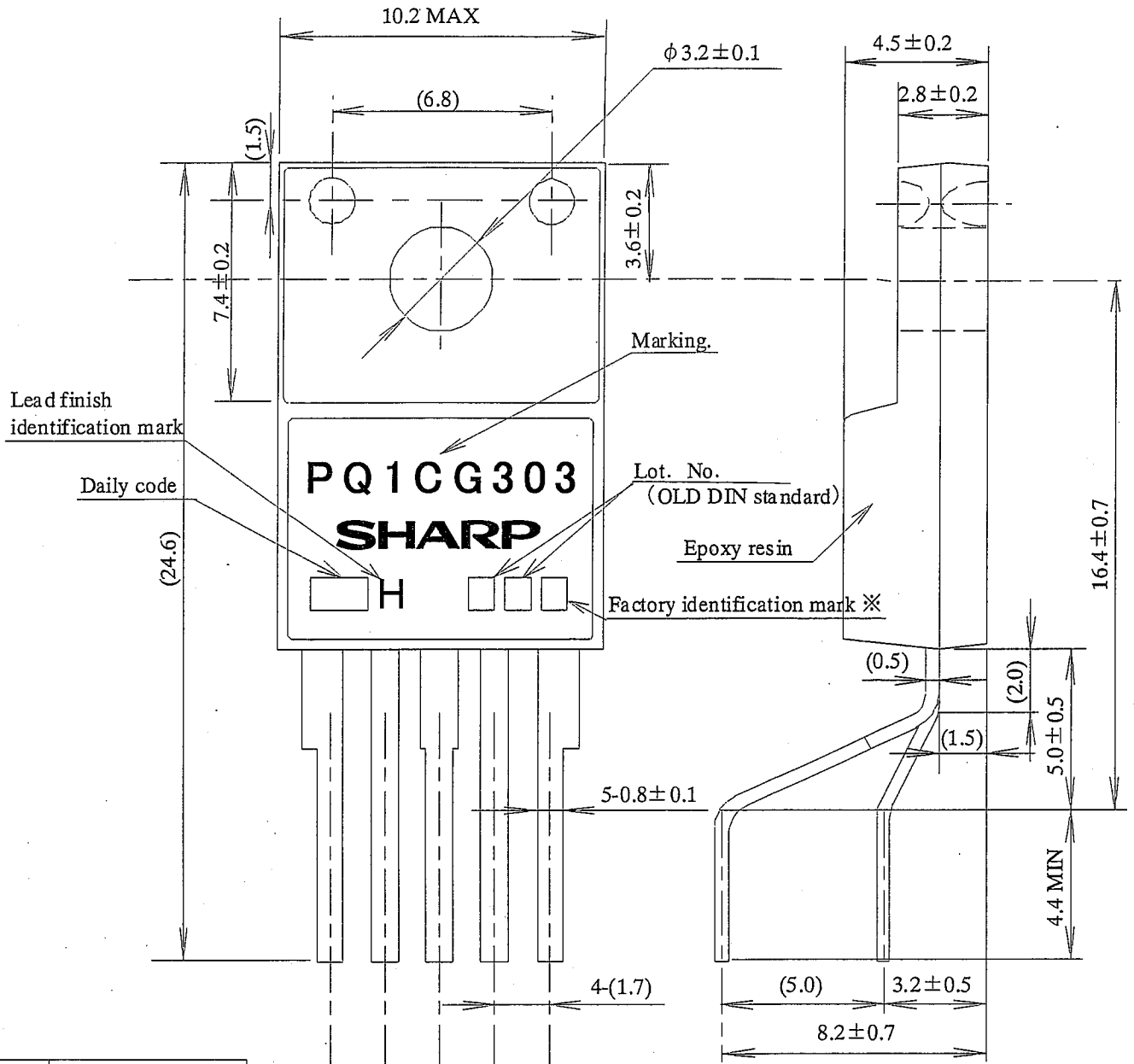

Date	Daily code indication
1	1
2	2
3	3
.	.
.	.
30	30
31	31

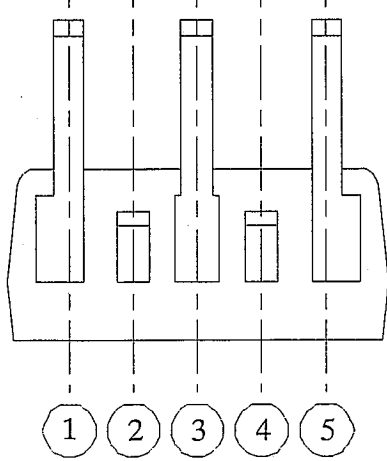

- () : TYP.
- Radius of lead forming portion
R = TYP 1.0
- Unit : mm
- Lead finish : Lead-free solder plating
(Composition:Sn2Cu)
- Lead material : Cu
- Product mass : (1.5g)

※ Without : Fujimoto Electric. Co., Ltd.
 ▲ : P.T.SHARP
 SEMICONDUCTOR INDONESIA

- ① VIN
- ② VOUT
- ③ COM
- ④ Oadj
- ⑤ ON/OFF

3. Rating and characteristics

3.1 Absolute maximum rating

 $T_a = 25^\circ\text{C}$

Parameter	Symbol	Rating	Unit	Conditions
Input voltage (*1)	V_{IN}	40	V	
Output adjustment pin voltage	V_{adj}	7	V	
Input-output voltage	V_{LO}	41	V	
Output-COM voltage (*2)	V_{OUT}	-1	V	
ON/OFF control voltage (*3)	V_c	-0.3 to 40.0	V	
Switching current	I_{sw}	3.5	A	
Power dissipation (*4)	P_{d1}	1.4	W	Refer to Fig. 1
	P_{d2}	14	W	
Junction temperature (*5)	T_j	150	$^\circ\text{C}$	
Operating temperature	T_{opr}	-20 to +80	$^\circ\text{C}$	
Storage temperature	T_{stg}	-40 to +150	$^\circ\text{C}$	
Soldering temperature	T_{sol}	260	$^\circ\text{C}$	For 10 s

(*1) Voltage between V_{IN} terminal and COM terminal.

(*2) Voltage between V_{OUT} terminal and COM terminal.

(*3) Voltage between ON/OFF control and COM terminal

(*4) P_{d1} : No heat sink, P_{d2} : With infinite heat sink

(*5) There is case that over heat protection function operates at the temperature $T_j = 125$ to 150°C , so this item cannot be used in this temperature range.

Fig. 1 Inner derating curve

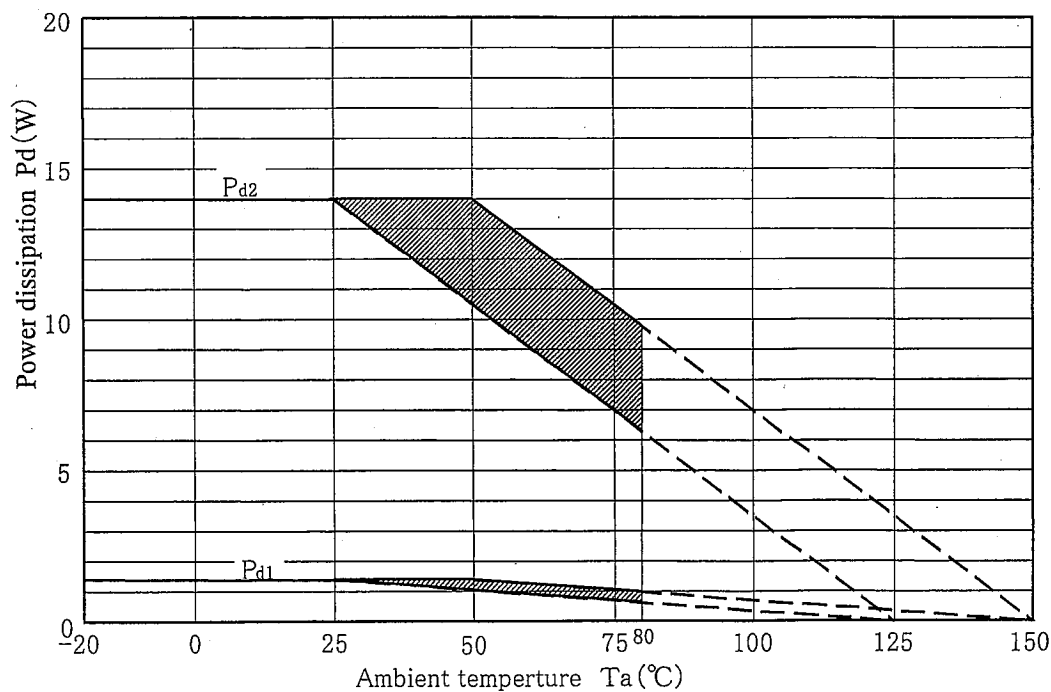

P_{d1} : No heat sink

P_{d2} : With infinite heat sink

(Note) There is case that over heat protection function operates at oblique line portion.

3.2 Electrical characteristics

Unless otherwise specified, condition shall be $V_{IN}=12V$, $I_o=0.5A$, $V_o=5V$, 5 pin : Open

$T_a=25^\circ C$

Parameter	Symbol	MIN.	TYP.	MAX.	Unit	Conditions
Output saturation voltage	V_{SAT}	-	1.4	1.8	V	$I_{sw}=3A$
Reference voltage	V_{REF}	1.235	1.260	1.285	V	
Temperature change in reference voltage	ΔV_{REF}	-	± 0.5	-	%	$T_j=0$ to $125^\circ C$
Load regulation	$ Reg_L $	-	0.2	1.5	%	$I_o=0.5$ to $3A$
Line regulation	$ Reg_I $	-	1	2.5	%	$V_{IN}=8$ to $35V$
Efficiency	η	-	80	-	%	$I_o=3A$
Oscillator frequency	f_o	135	150	165	kHz	
Temperature change in oscillator frequency	Δf_o	-	± 2	-	%	$T_j=0$ to $125^\circ C$
Over current detector level	I_L	3.6	4.7	5.8	A	I_{sw} (peak)
Charging current	I_{CHG}	-	-10	-	μA	2, 4 pin : Open 5 pin
Input threshold voltage	V_{THL}	-	1.3	-	V	Duty=0%, 5 pin 4 pin=0V
	V_{THH}	-	2.3	-	V	Duty=100%, 5 pin 4 pin : Open
On threshold voltage	V_{THON}	0.7	0.8	0.9	V	4 pin=0V, 5 pin
Stand-by current	I_{SD}	-	140	400	μA	$V_{IN}=40V$, 5 pin=0V
Output off-state consumption current	I_{OS}	-	8	16	mA	$V_{IN}=40V$ 5 pin=0.9V

3.3 Electrical characteristics measuring circuit

Fig. 2 Standard measuring circuit

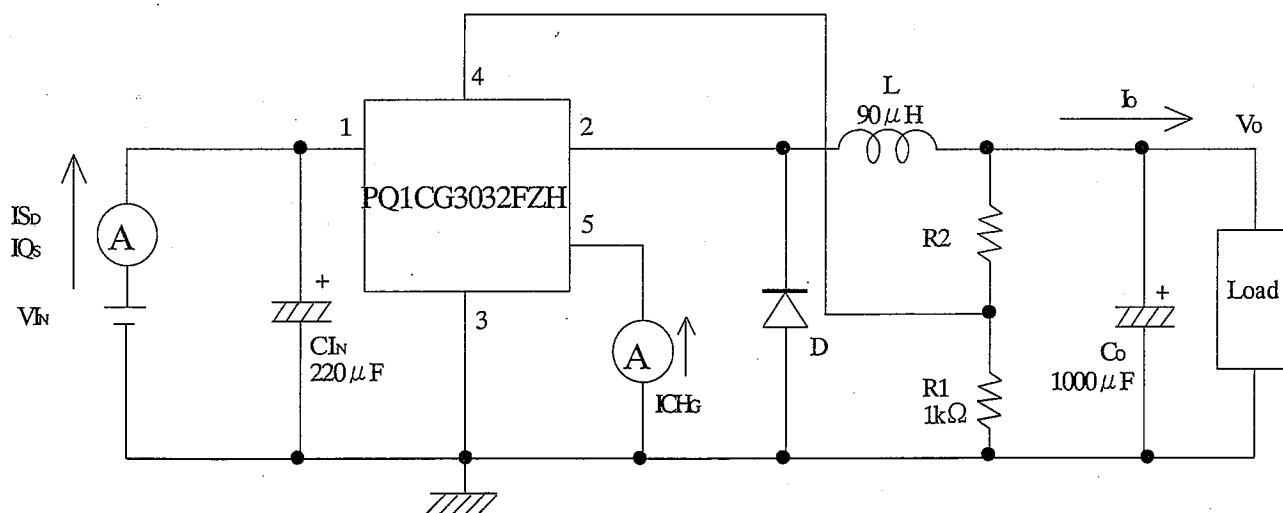

L: HK-12S120-9000R (TOHO ZINC CO., LTD.)

D: YG811S04R (FUJI ELECTRONIC COMPONENTS, LTD)

ON/OFF control logic

5 pin	Output
LOW	OFF
HIGH	ON
OPEN	ON

4. Reliability

The reliability of products shall satisfy items listed below.

Confidence level : 90%

LTPD : 10 or 20

Test Items	Test Conditions	Failure Judgment Criteria	Samples (n)
			Defective(C)
Temperature cycling	1 cycle -40°C(30min) to +150°C(30min) 20 cycles test	$V_{REF} < L \times 0.8$ $V_{REF} > U \times 1.2$ $f_o < L \times 0.8$ $f_o > U \times 1.2$ $ RegL > U \times 1.2$ $ RegI > U \times 1.2$ $V_{SAT} > U \times 1.2$	n=22, C=0
Humidity (Steady State)	+60°C, 90%RH, 1000h		n=22, C=0
Damp Heat cycling	1 cycle : -20°C(2h) to 70°C(2h) Transfer time between high and low temp. is 1h.40 cycles test, 90%RH		n=22, C=0
High temp. storage	+150°C, 1000h		n=22, C=0
Low temp. storage	-40°C, 1000h		n=22, C=0
Operation life	Ta=25°C, Pd=1.4W, Without radiator plate, 1000h		n=22, C=0
Mechanical shock	15km/s ² , 0.5ms each 3 times/ ±X, ±Y, ±Z		n=11, C=0
Vibration (Variable frequency)	200m/s ² 100 to 2000 to 100Hz/4 min each 4 times/ X, Y, Z direction		n=11, C=0
Soldering heat	260°C, 10 s, Dip it into solder to the position of 1.5mm from resin portion *3		n=11, C=0
Electrostatic discharge	±250V, 200pF, 0Ω Between GND and each terminal/ each 3 times		n=11, C=0
Robustness of Termination (Tensile test)	Weight: 10N 30 s/ each terminal		Failure if it has breakdown and loosened pin (Except transformation of terminal)
Robustness of Termination (Bending test)	Weight: 2.5N 0° ~90° ~0° ~-90° ~0° each terminal *2	n=11, C=0	
Solderability	245±2°C, 3 s Solder : Sn/3.0Ag/0.5Cu Use EC19S(TAMURA KAKEN Corporation made flux) *3	Failure if solder does not adhere on to the area of 95% or more in A portion.	n=11, C=0

*1 Although color of terminals may change, this change of color is not included in criteria of failure judgment.

*2 Terminal bending direction is shown below.

*3 Soldering area is shown below.

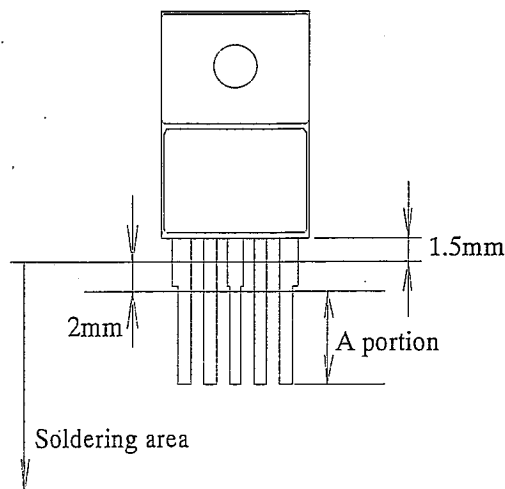
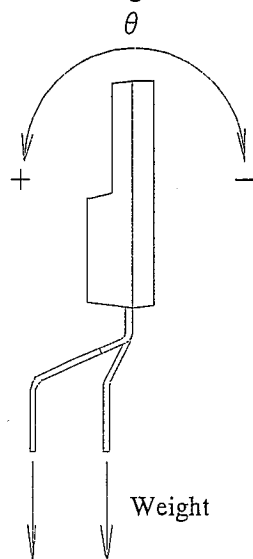

REFERENCE

5. Outgoing inspection

A single sampling plan, normal inspection level II based on ISO 2859 is applied.

The AQL according to the inspection items are shown below.

Defect	Inspection items	AQL(%)	Judgment criteria
Major defect	Electrical characteristics	0.1	It is based on the contents in the specification.
	Marking		To be recognized.
Minor defect	Dimensions	0.4	It is based on the contents in the specification.
	Appearance		Having no resin break off and lead bending.

6. Supplement

6.1 Example of application

Step down type circuit diagram

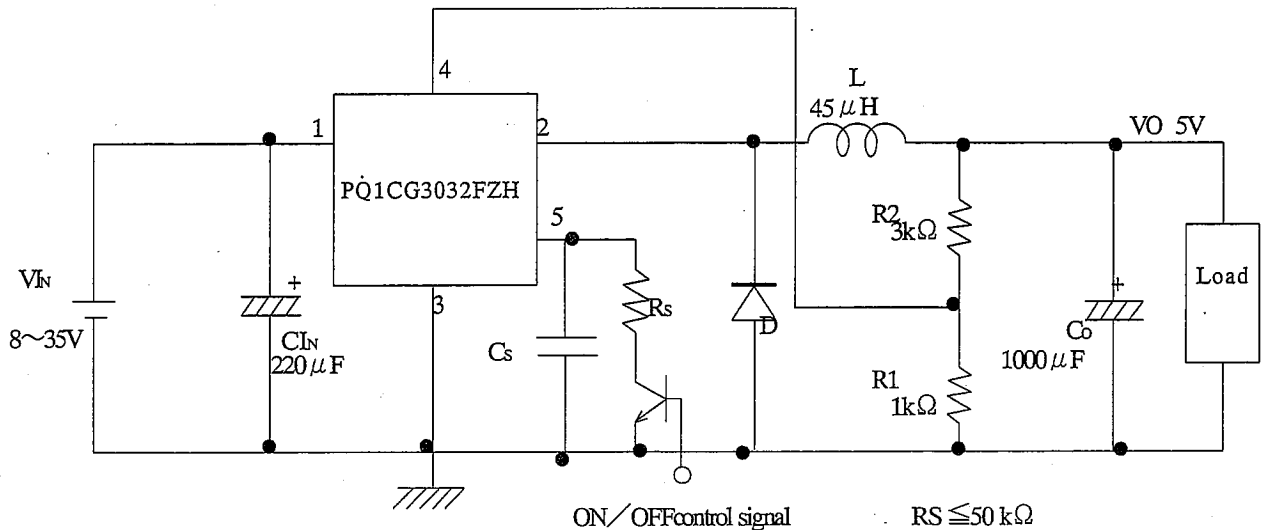

Polarity invert type circuit diagram

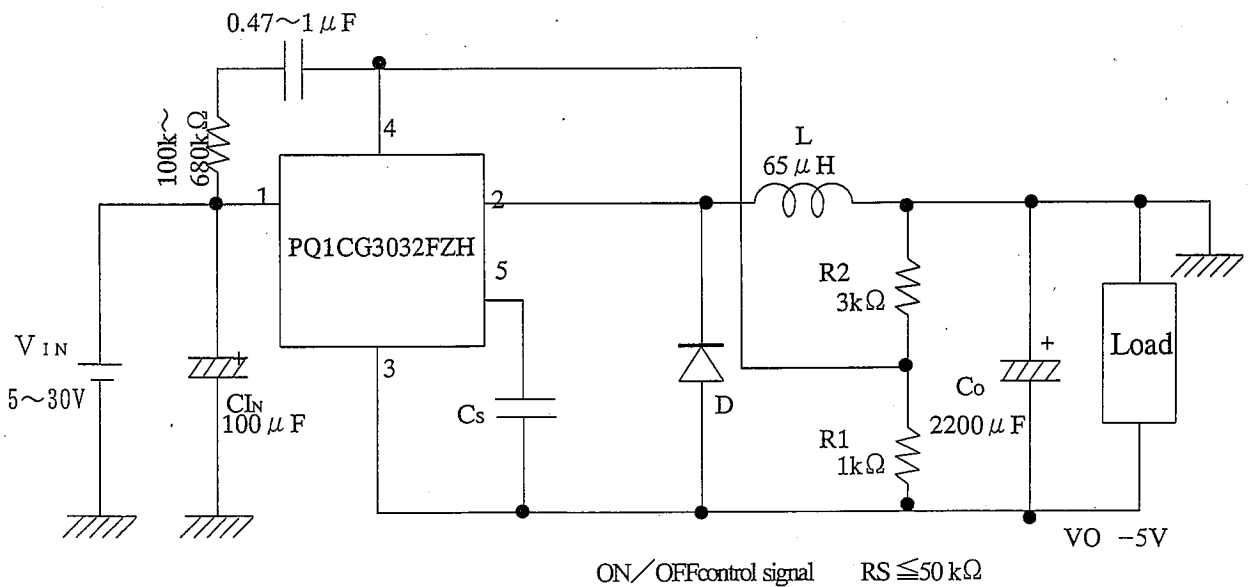

In case that polarity is reverse, depending on the conditions, there is cases that output voltage can not gain, please use this device after confirming at the actual conditions.

REFERENCE

6.5 Packing specification

- (1) MAX. 50pcs. of products shall be packaged in a sleeve and both of sleeve edges shall be fixed by stoppers.
- (2) MAX. 10 sleeves (5 lines × 2 stairs) above shall be packaged in a outer case.
- (3) Packing case shall be enclosed with kraft tape.

The description of contents on the side of outer packing case shall be marked as follows;

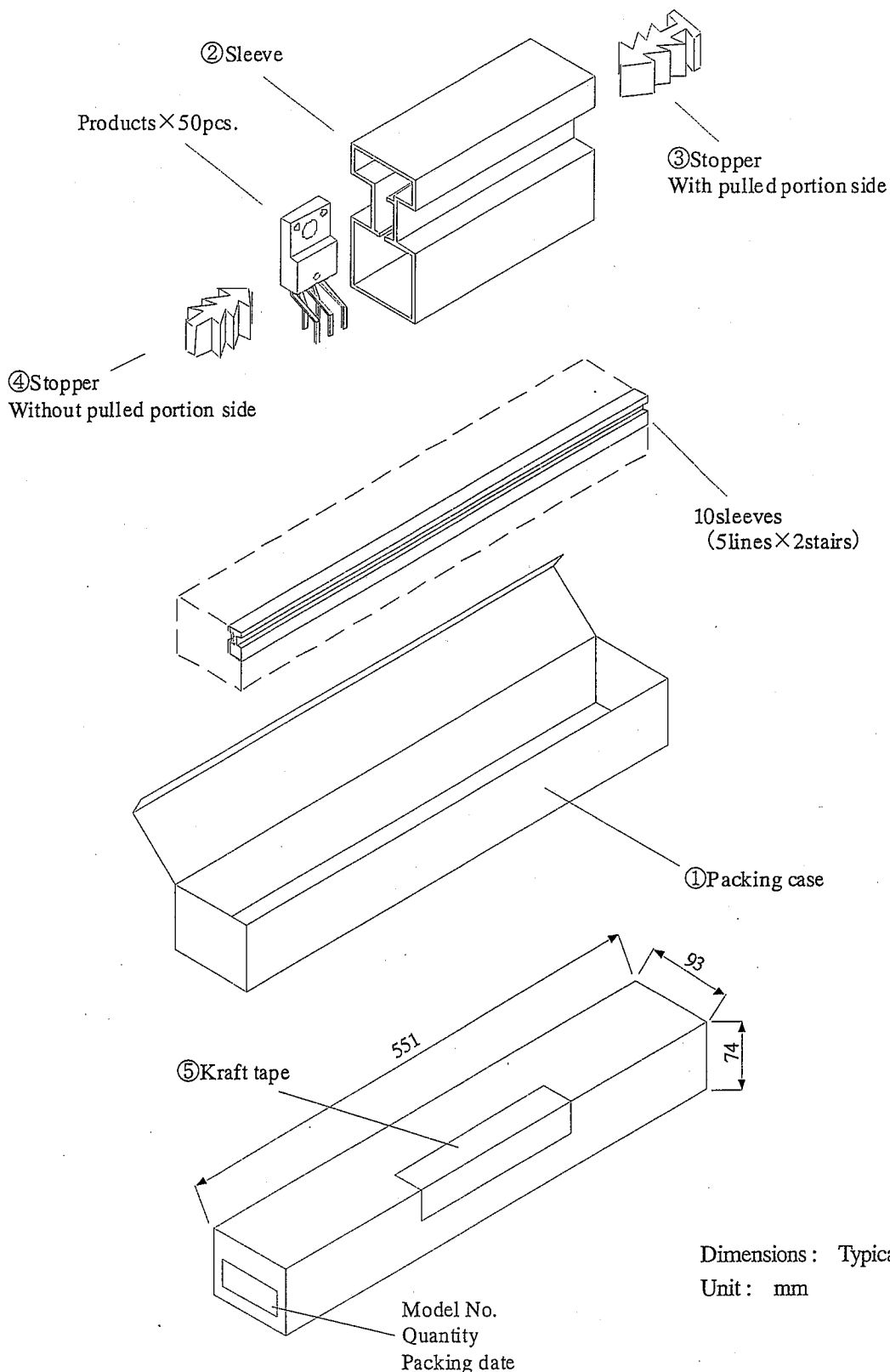

• Product mass at 500pcs./package : Approximately 1.5kg

7. Notes

7.1 External connection

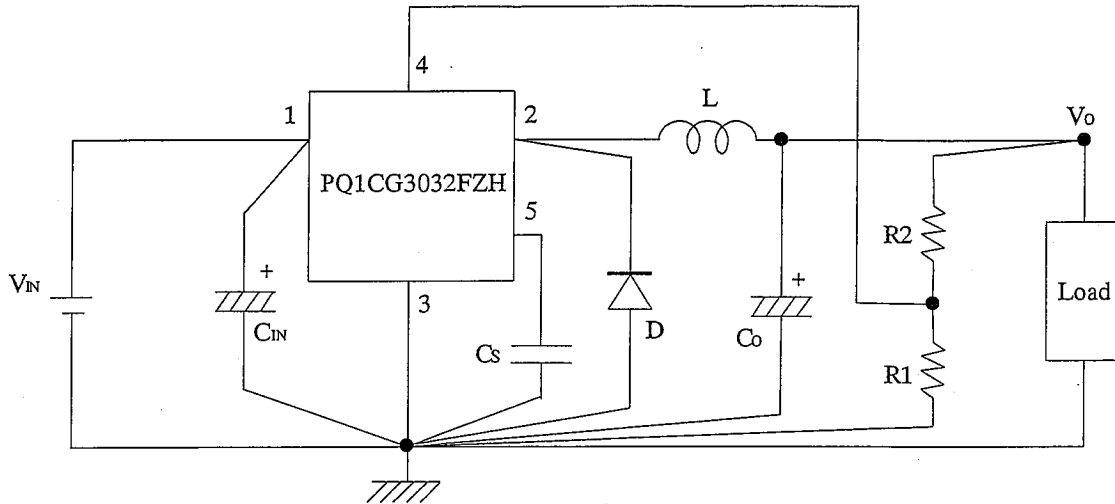

- (1) Layout is very important, Rapidly switching currents associated with wiring inductance generate voltage transients which can cause problems. For minimal inductance and ground loops, the length of the leads indicated by heavy lines should be kept as short as possible.
- (2) Fast switching speed and low forward voltage type schottky barrier diode should be recommended for the catch-diode because it affects the efficiency. Please use the catch-diode which current rating is at least 1.2 times as much as maximum load current.
- (3) The output ripple voltage is highly influenced by ESR (Equivalent Series Resistor), and can be minimized by selected Low ESR capacitor.
- (4) An inductor should not be operated beyond its maximum rated current because it may saturate.
- (5) When voltage that is higher than V_{IN} ①, is applied to V_{OUT} ②, there is the case that the device is broken. Especially, in case V_{IN} ① is shorted to GND in normal condition, there is the case that the device is broken since the charged electric charge in output capacitor (C_O) flows into input side. In such case a schottky barrier diode or a silicon diode shall be recommended to connect as the following circuit.

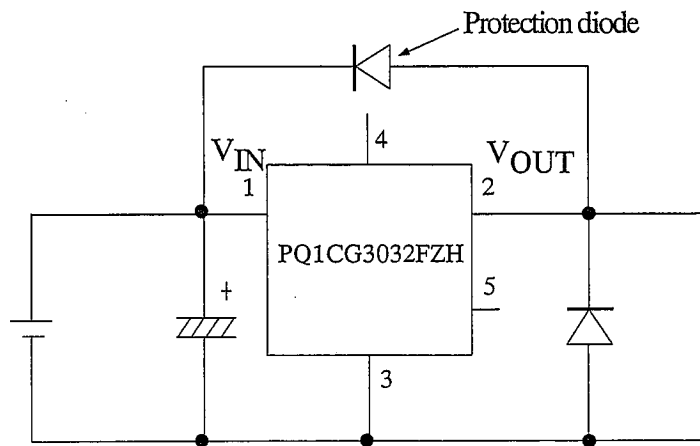

7.2 Thermal protection design

Internal power dissipation (P) of device is obtained by the following equation.

$$P = I_{SW}(\text{Average}) \times V_{SAT} \times D' + V_{IN} (V_{IN} \text{ to COM terminal}) \times I_Q (\text{consumption current})$$

Step down type

$$D' (\text{Duty}) = \frac{T_{ON}}{T (\text{Period})} = \frac{V_O + V_F}{V_{IN} - V_{SAT} + V_F}$$

$$I_{SW} (\text{Average}) = I_O (\text{Output current})$$

Polarity invert type

$$D' (\text{Duty}) = \frac{T_{ON}}{T (\text{Period})} = \frac{|V_O| + V_F}{V_{IN} + |V_O| - V_{SAT} + V_F}$$

$$I_{SW} (\text{Average}) = \frac{1}{1-D'} \times I_O$$

V_F : Forward voltage of the diode

When the ambient temperature and Pd (MAX.) in a operating state of the device,, use such a heat sink as allows the element to operate within the safety operation area specified by the derating curve in 3.1 Fig. 1. Insufficient radiation or using over the limitation of the inner power dissipation curve gives an unfavorable influence to the normal operation and reliability of the device.

When deviating from the safety operational territory illustrated by the derating curve, the overheat protection circuit operates to shut down output, please avoid keeping such condition for a long time.

7.3 Adjustment of output voltage

Output voltage can be adjustable by loading external resistor R1 and R2 in to pin No. 3, No. 4 terminal.

Adjustable range as follows ;

Step down voltage type

$$V_O = V_{REF} \text{ to } 35V (\text{Max. rating is limited by } (V_{IN} - V_{SAT}) \text{ according to input voltage})$$

Polarity inversion type

$$V_O = -V_{REF} \text{ to } -30V (\text{Absolute max. rating is limited by } 40 - V_{IN} \text{ according to input voltage})$$

$$\text{Output voltage } |V_O| = V_{REF} \times (1 + R_2/R_1) \quad (V)$$

$$R_1 \text{ recommended range : } 0.7k\Omega \leq R_1 \leq 3k\Omega$$

7.4 ON/OFF control terminal in the following circuit

〈ON/OFF control〉

When transistor Tr becomes ON and ON/OFF control terminal becomes low, output voltage can be turned OFF and become stand-by mode.

Stand-by mode current dissipation becomes Max. $400 \mu\text{A}$.

When transistor Tr becomes OFF, output voltage can be ON.

〈Soft startup〉

When capacitor Cs is loaded, output pulse gradually expanded and output voltage will start softly.

〈ON/OFF control with soft startup〉

External resistor Rs should be leaded to avoid discharge current of Cs, and not to break the transistor Tr.

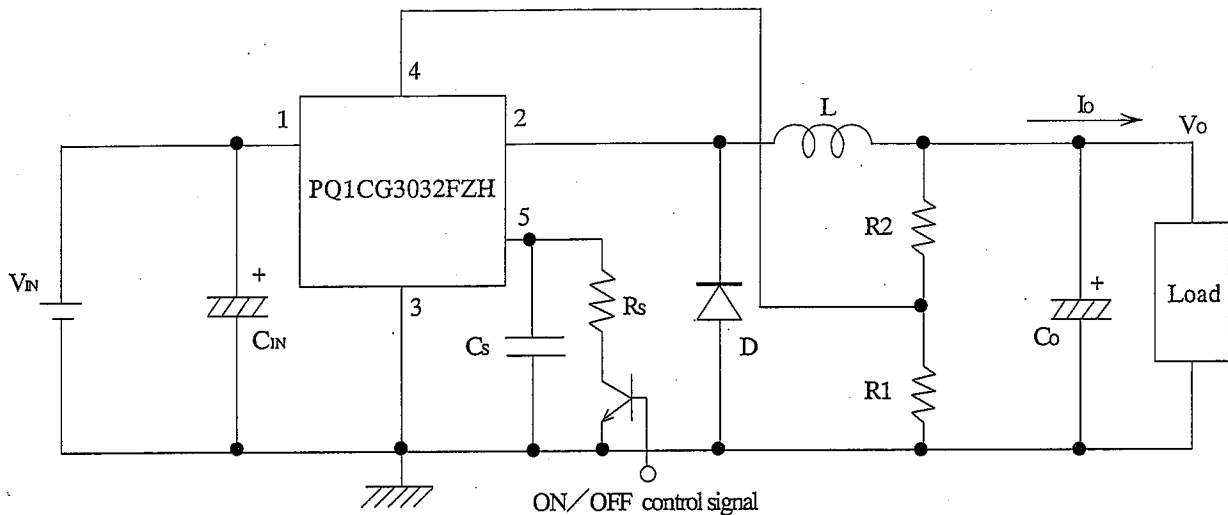

Step down type circuit diagram

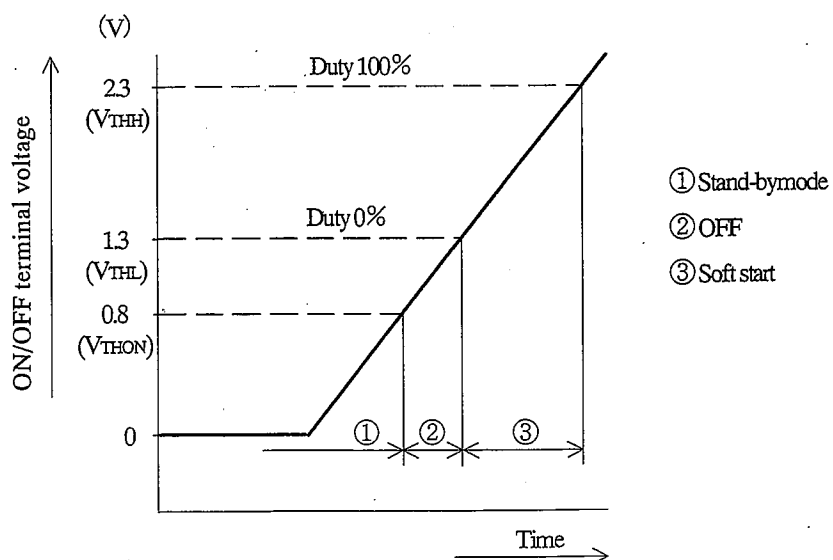

7.5 Mounting

Please fix the device on the heat sink with tightening torque of 0.4 to 0.5N · m by using M3 screw.
Then, please pay attention so that mechanical force shall not be loaded to the terminal and mold resin.

Strictly observe the following items to effectively radiate the heat generated in the device.

- (a) Warp and unevenness shall not occur on the contact surface of the heat sink and device.
- (b) Metal dust and metal burr shall not be attached to the contact surface of the heat sink and device.
- (c) Uniformly apply silicone grease on the contact surface of the heat sink and device.

Please select the grease having no secular alteration in the operating temperature range. And, grease to be used

- ① No secular variation in operating temperature range.
- ② Base oil does not separate and it does not permeate in the device.
- ③ Please select the base oil which does not exert a bad influence on the device's operation and life if the oil permeates the device.

For example, we recommend G-746; Shin-Etsu Chemical Co., Ltd. and SC-102; Dow Corning Toray Co., Ltd.

7.6 Static electricity

Good caution must be exercised against static electricity since this device consists of a bipolar IC.

Following are some examples of preventive measures against excessive voltages such as caused by static electricity.

- (a) Human body must be grounded to discharge the static electricity from the body or cloth.
- (b) Anything that is in contact with the device such as workbench, inserter, or measuring instrument must be grounded.
- (c) Use a solder dip basin with a minimum leak current (isolation resistance 10M Ω or more) from the commercial power supply. Also the solder dip basin must be grounded.

7.7 Cleaning

- (1) Solvent cleaning : Solvent temperature 45°C or less, Immersion for 3 min or less
- (2) Ultrasonic cleaning : The effect to device by ultrasonic cleaning differs by cleaning bath size, ultrasonic power output, cleaning time, PCB size or device mounting condition etc.
Please test it in actual using condition and confirm that doesn't occur any defect before starting the ultrasonic cleaning.
- (3) Applicable solvent : Ethyl alcohol, Methyl alcohol, Isopropyl alcohol
When the other solvent is used, there are cases that the packaging resin is eroded.
Please use the other solvent after thorough confirmation is performed in actual using condition.

7.8 Storage environment

The products shall be stored at the temperature 5 to 30°C and the humidity 70%RH or less, avoiding direct sunlight.

Regarding the devices stored for long time, there is possibility that deterioration of lead pin color and solderability may be caused. Please use the devices after checking the solderability in advance.

7.9 Hand soldering

This device is basically designed for reflow soldering, if it is necessary to do hand soldering for modification, please use a soldering iron which is countermeasured for static electricity.

Temperature of soldering iron tip should be less than 380°C. Time for soldering should be within 3 seconds each terminals. Number of times should be only one time. Please be careful not to give any external force on terminals by soldering iron. For example, soldering iron should not touch terminals directly.

7.10 Input voltage to Oadj terminal

In case that ripple voltage of output is high, ripple voltage to Oadj voltage becomes high also and frequency of the chopper regulator may change. Especially under low temperature, impedance of an output capacitor increases and it makes the ripple voltage of output increase.

Therefore, please evaluate the device thoroughly on this point and make sure that it works under actual usage conditions.