

PR3BMF51NSLF

$I_T(\text{rms}) \leq 1.2\text{A}$, Non-Zero Cross type
DIP 8pin
Triac output SSR



■Description

PR3BMF51NSLF Solid State Relay (SSR) is an integration of an infrared emitting diode (IRED), a Phototriac Detector and a main output Triac. This device is ideally suited for controlling high voltage AC loads with solid state reliability while providing 4kV isolation ($V_{\text{iso}}(\text{rms})$) from input to output.

■Features

1. Output current, $I_T(\text{rms}) \leq 1.2\text{A}$
2. Non-zero crossing functionary
3. 8 pin DIP package
4. High repetitive peak off-state voltage ($V_{\text{DRM}} : 600\text{V}$)
5. Superior noise immunity ($dV/dt : \text{MIN. } 100\text{V}/\mu\text{s}$)
6. Response time, $t_{\text{on}} : \text{MAX. } 100\mu\text{s}$
7. High isolation voltage between input and output ($V_{\text{iso}}(\text{rms}) : 4\text{kV}$)
8. RoHS directive compliant

■Agency approvals/Compliance

1. Approved by UL file No.E94758 (as model No.**R3BMF5**)
2. Approved by CSA file No.LR63705 (as model No.**R3BMF5**)
3. Optionary approved by VDE (DIN EN 60747-5-5), file No.40008898 (as model No.**R3BMF5**)
4. Package resin : UL flammability grade (94V-0)

■Applications

1. Isolated interface between high voltage AC devices and lower voltage DC control circuitry.
2. Switching motors, fans, heaters, solenoids, and valves.
3. Phase or power control in applications such as lighting and temperature control equipment.

Notice The content of data sheet is subject to change without prior notice.

In the absence of confirmation by device specification sheets, SHARP takes no responsibility for any defects that may occur in equipment using any SHARP devices shown in catalogs, data books, etc. Contact SHARP in order to obtain the latest device specification sheets before using any SHARP device.

Sheet No.: OP14009EN

■ Pin-Number and internal connection diagram

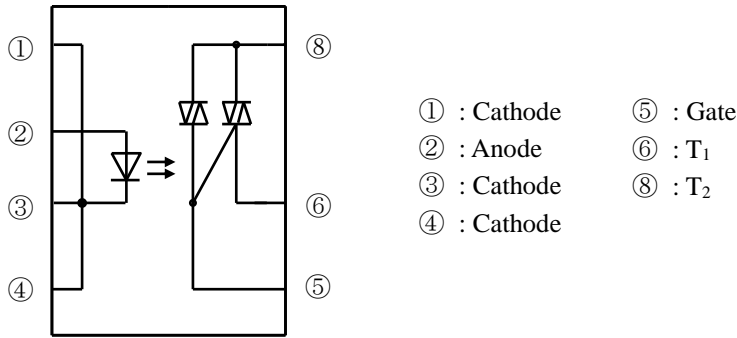

■ Outline

Burr Max. 0.2

Brand name "S"

1.2^{+0.3}

1.05^{+0.20}

Anode mark

Factory identification mark *2

Date Code *1

Business dealing name identification mark *3

Rank mark

R3BMF5

2.54^{+0.25}

6.5±0.5

7.62^{+0.30}

Epoxy resin

0.26^{+0.10}

θ

$\theta: 0 \sim 13^\circ$

9.66^{+0.50}

3.5±0.5

0.5TYP.

2.9±0.5

3.25±0.50

0.5±0.1

Marking is laser marking

*1) 2-digit number shall be marked according to OLD DIN standard.

*2) Factory identification mark applies to the below.
 Without : SUN-S Corporation (Japan)
 : SUN-S Electronic Technology (KUNSHAN) Co. Ltd (China)

*3) Business dealing name identification mark : —

Product mass : Approx. 0.56g

UNIT : 1/1 mm

Name	R3BMF5 Outline Dimensions (Business dealing name : PR3BMF51NSLF)
------	---

Pin material : Copper Alloy
 Pin finish : SnCu plating (Cu : TYP. 2%)

■ Absolute maximum ratings

Ta=25°C

Parameter		Symbol	Rating	Unit
Input	Forward current *1	I _F	50	mA
	Reverse voltage	V _R	6	V
Output	RMS on-state current *1	I _{T(rms)}	1.2	A
	Peak one cycle surge current *2	I _{surge}	12	A
	Repetitive peak off-state voltage	V _{DRM}	600	V
Isolation voltage *3		Viso(rms)	4.0	kV
Operating temperature		Topr	-30 to +85	°C
Storage temperature		Tstg	-40 to +125	°C
Soldering temperature *4		Tsol	270	°C

*1 The derating factors of absolute maximum rating due to ambient temperature are shown in Fig.1, 2.

*2 50Hz sine wave

*3 AC for 1min, 40 to 60%RH, f=60Hz

*4 For 10s

■ Electrical Characteristics

Ta=25°C

Parameter		Symbol	MIN.	TYP.	MAX.	Unit	Conditions
Input	Forward voltage	V _F	-	1.2	1.4	V	I _F =20mA
	Reverse current	I _R	-	-	10	μA	V _R =3V
Output	Repetitive peak off-state current	I _{DRM}	-	-	100	μA	V _D =V _{DRM}
	On-state voltage	V _T	-	-	2.5	V	I _T =1.2A
	Holding current	I _H	-	-	25	mA	V _D =6V
	Critical rate of rise of off-state voltage	dv/dt	100	-	-	V/μs	V _D =(1/√2)·V _{DRM}
Transfer characteristics	Minimum trigger current	I _{FT}	-	-	10	mA	V _D =6V, R _L =100Ω
	Isolation resistance	R _{ISO}	5×10 ¹⁰	10 ¹¹	-	Ω	DC500V 40 to 60%RH
	Turn on time	t _{ON}	-	-	100	μs	V _D =6V, R _L =100Ω, I _F =20mA

Fig.1 Forward current vs. ambient temperature(*1)

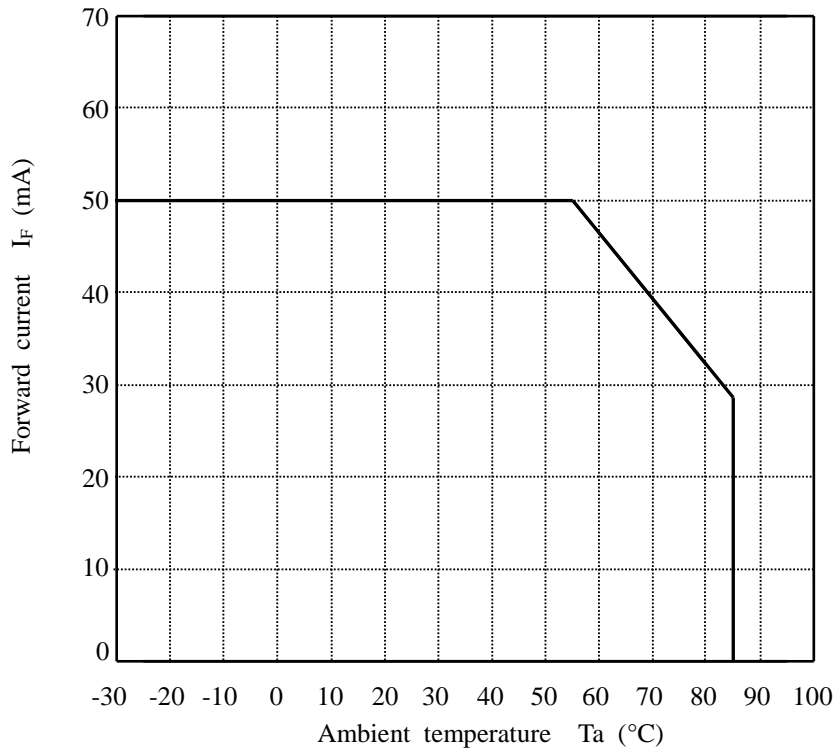
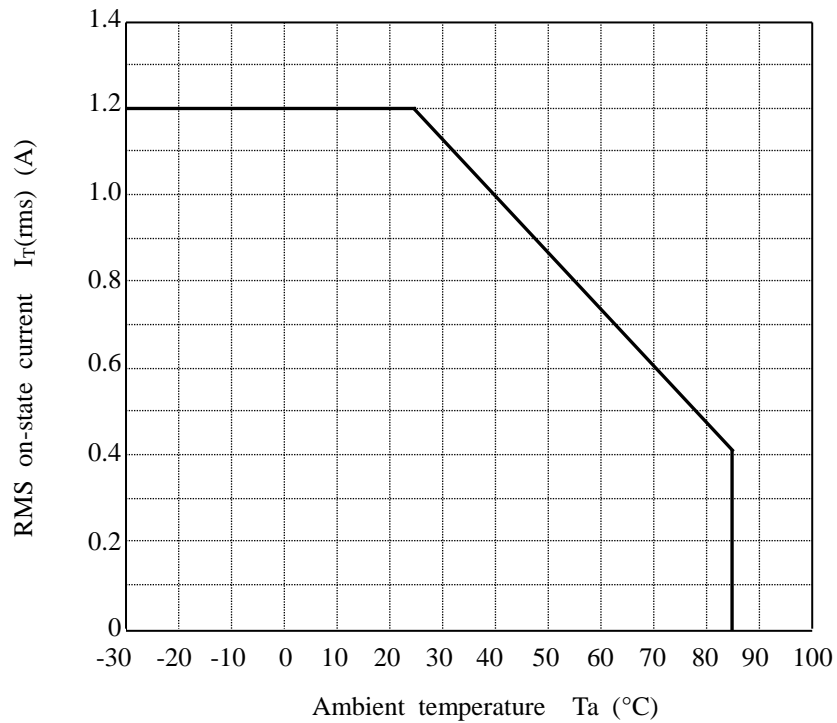



Fig.2 RMS on-state current vs. ambient temperature(*1)



*1 Mounting conditions
 No heat sink
 Paper phenol board : 100mm×100mm×1.6mm
 All pins should be installed in the print board with soldering.
 Whole solder landing dimensions : 140mm²

■ **Supplement**

- Isolation voltage shall be measured in the following method.
 - (1) Short between anode and cathode on the primary side and between anode, cathode and gate on the secondary side.
 - (2) The dielectric withstanding tester with zero-cross circuit shall be used.
 - (3) The wave form of applied voltage shall be a sine wave.
(It is recommended that the isolation voltage be measured in insulation oil.)
- This Model is approved by UL and CSA.
Approved Model No. : R3BMF5
 1. UL file No. : E94758
 2. CSA file No. : LR63705
 CSA approved mark "  " and rating shall be indicated on minimum unit package.

- This product is not designed against irradiation.
This product is assembled with electrical input and output.
This product incorporates non-coherent light emitting diode.
- ODS materials
This product shall not contain the following materials.
Also, the following materials shall not be used in the production process for this product.
Materials for ODS : CFCs, Halon, Carbon tetrachloride, 1.1.1-Trichloroethane (Methyl chloroform)
- Brominated flame retardants
Specified brominated flame retardants (PBB and PBDE) are not used in this device at all.
- Compliance with each regulation
 - 1) The RoHS directive (2002/95/EC)
This product complies with the RoHS directive (2002/95/EC).
Object substances: mercury, lead (except for lead in high melting temperature type solders*¹ and glass of electronic components), cadmium, hexavalent chromium, polybrominated biphenyls (PBB) and polybrominated diphenyl ethers (PBDE)
*1 : i.e. tin-lead solder alloys containing more than 85% lead
 - 2) Content of six substances specified in Management Methods for Control of Pollution Caused by Electronic Information Products Regulation (Chinese : 电子信息产品污染控制管理办法).

Category	Toxic and hazardous substances					
	Lead (Pb)	Mercury (Hg)	Cadmium (Cd)	Hexavalent chromium (Cr ⁶⁺)	Polybrominated biphenyls (PBB)	Polybrominated diphenyl ethers (PBDE)
Solid State Relay	*	✓	✓	✓	✓	✓

✓ : indicates that the content of the toxic and hazardous substance in all the homogeneous materials of the part is below the concentration limit requirement as described in SJ/T 11363-2006 standard.

* : indicates that the content of the toxic and hazardous substance in at least one homogeneous material of the part exceeds the concentration limit requirement as described in SJ/T 11363-2006 standard.

Lead in high melting temperature type solders (i.e. tin-lead solder alloys containing more than 85% lead) and glass of electronic components (designated by “*” in the above table) are exempt from the RoHS directive (2002/95/EC), because there is no effective way to eliminate or substitute them by present scientific technology.

■Notes

●Circuit designing

(1) Trigger current

The LED used in the Solid state relay generally decreases the light emission power by operation.

In case of long operation time, please decide I_F value so that I_F is twice or more of the Maximum value of the Minimum triggering current at circuit design with considering the decreases of the light emission power of the LED. (50%/5years)

(2) Snubber circuit

This device doesn't have built-in snubber circuit.

To avoid the false operation and protect SSR, please locate the appropriate snubber circuit between output pins base by the load. (Recommendable values : $R_s=47\Omega$, $C_s=0.022\mu F$)

Particularly, in case the device is used for the load such as solenoid valves and motors, false operation may happen in off-state due to rapid change of voltage at output pins caused by the phase difference of load current. So please be sure to locate the snubber circuit ($R_s=47\Omega$, $C_s=0.022\mu F$) and make sure the device works properly in actual conditions.

In addition, the values of snubber circuit may have to be changed if necessary after tested in actual conditions.

(3) Off-state input current

Input current (I_F) at off-state shall be set 0.1mA or less.

(4) Pulse drive

In case that pulse drive is carried out, the pulse width of input signal should be 1ms or more.

(5) If the voltage exceeding the repetitive peak off-state voltage (V_{DRM}) in the absolute maximum ratings is applied to the phototriac, it may cause not only faulty operation but breakdown.

Make sure that the surge voltage exceeding V_{DRM} shall not be applied by using the varistor, CR.

●Cleaning

(1) Solvent cleaning : Solvent temperature 45°C or less Immersion for 3 min or less

(2) Ultrasonic cleaning : The effect to device by ultrasonic cleaning differs by cleaning bath size, ultrasonic power output, cleaning time, PCB size or device mounting condition etc.

Please test it in actual using condition and confirm that any defect doesn't occur before starting the ultrasonic cleaning.

(3) Applicable solvent : Ethyl alcohol, Methyl alcohol, Isopropyl alcohol

In case the other solvent is used, there are cases that the packaging resin is eroded.

Please use the other solvent after thorough confirmation is performed in actual using condition.

●Using method

As to this product, all pin shall be used by soldering on the print wiring board. (Socket and others shall not be used.)

●Precautions for Soldering

(1) In case of flow soldering (Avoid immersing the resin part in the solder.)

It is recommended that flow soldering be carried out at 270°C or less and within 10s

(Pre-heating:100 to 150°C, 30 to 80s) : Within 2 times

(2) In case of hand soldering

It is recommended that hand soldering be carried out at 400°C or less and within 3s: Within 2 times

(3) Other precautions

Depending on equipment and soldering conditions (temperature, Using solder etc.), the effect to junction between PCB and lead pins of the device is different.

Please confirm that there is no problem on the actual use conditions

■ Package specification

● Package materials

No.	Name	Materials	Purposes
①	Sleeve	HIPS or ABS with preventing static electricity	Products packaged
②	Stopper	Styrene-Elastomer	Products fixed
③	Packing case	Corrugated cardboard	Sleeve packaged
④	Kraft tape	Paper	Lid of packaged case fixed
⑤	Label	Paper	Model No. (Business dealing name), Lot No. Quantity, Country of origin, Company name and Inspection date specified

● Package method

- (1) MAX. 50pcs. of products shall be packaged in a sleeve ① and both of sleeve edges shall be fixed by stoppers ②.
- (2) MAX. 20 sleeves (Product : 1000pcs) above shall be packaged in a packing case ③.
- (3) The label ⑤ shall be put on the side of the packing case.
- (4) Case shall be closed with the lid and enclosed with kraft tape ④.

● Sleeve outline dimensions

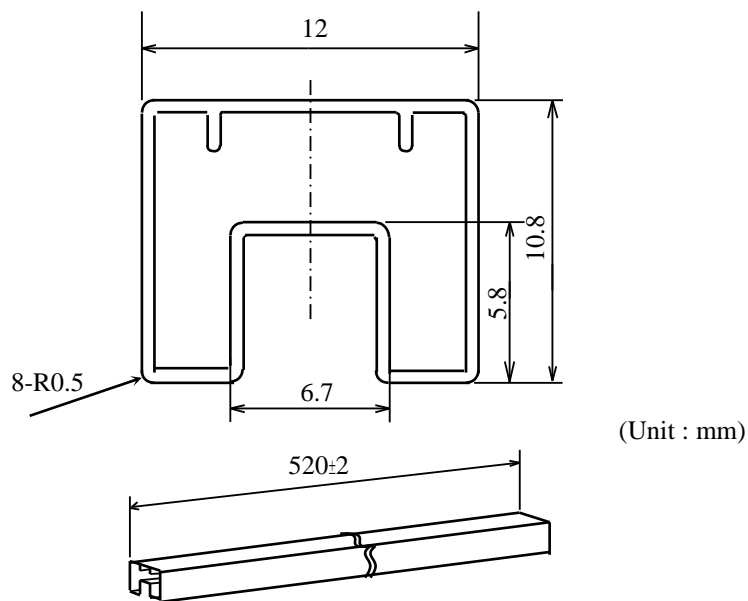

- Note
- 1) Thickness : 0.5±0.2mm
 - 2) Process with applying antistatic treatment.
 - 3) Unless otherwise specified tolerances shall be ±0.5mm.
(However except for deformation due to the rubber stopper in sleeve.)

●Packaging case outline dimensions

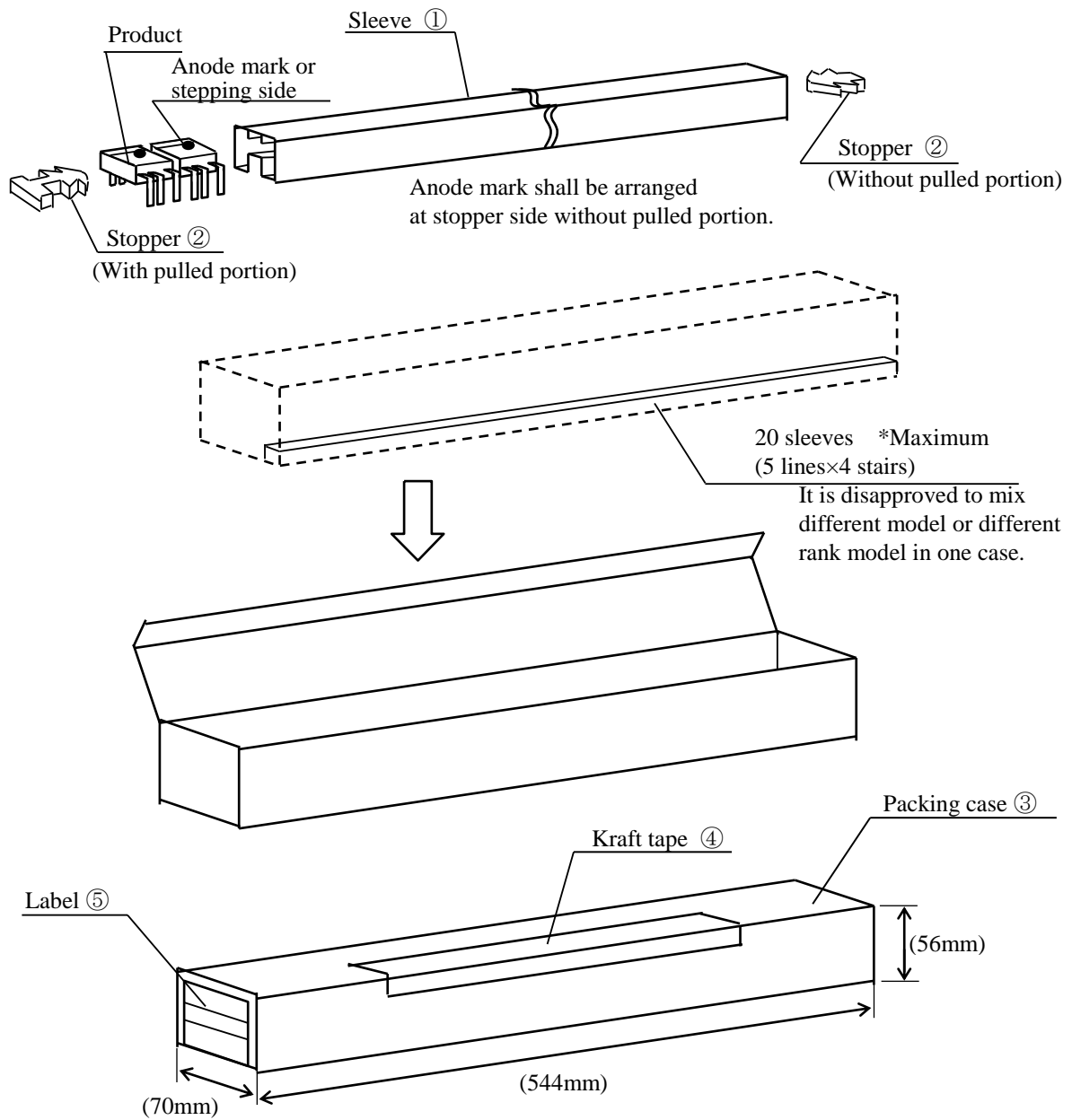

Regular packing mass : Approx.970g
 () : Reference dimensions

(Attachment-1-1)

- This specification shall be applied to Solid State Relay (SSR), Model No. R3BMF5 series as an option.
- Applicable Models (Business dealing name)
PR3BMF51YSLF
- The relevant models are the models Approved by VDE according to DIN EN 60747-5-5
VDE approved No. : 40008898

Approved Model No. : R3BMF5

- Operating isolation voltage $V_{IORM(peak)}$: 890V
- Transient voltage $(Peak)$: 7100V
- Pollution : 2
- Clearances distance (Between input and output) : 6.4mm (MIN.)
- Creepage distance (Between input and output) : 6.4mm (MIN.)
- Isolation thickness between input and output : 0.15mm (MIN.)
- Tracking-proof : CTI 175
- Safety limit values
Current (Isi) : 200mA (Diode side)
Power (Psi) : 3600mW (Triac side)
Temperature (Tsi) : 150°C

In order to keep safety electric isolation of photocoupler, please set the protective circuit to keep within safety limit values when the actual application equipment troubled.

- Indication of VDE approval "  " is printed on minimum unit package.

- Outline Refer to the attachment-1-2.

- Isolation specification according to EN 60747-5-5

Parameter	Symbol	Condition	Rating	Unit	Remark
Class of environmental test	-	-	30/100/21	-	
Pollution	-	-	2	-	
Maximum operating isolation voltage	$V_{IORM(PEAK)}$	-	890	V	
Partial discharge test voltage (Between input and output)					
Diagram 1	$V_{m(PEAK)}$	$t_m=10s,$ $q_c<5pC$	1340	V	Refer to the Diagram 1, 2 (Attachement-1-3)
Diagram 2		$t_{st1}=1s,$ $q_c<5pC$	1670	V	
Maximum over-voltage	$V_{ini,a(PEAK)}$	$t_{mi}=60s$	7100	V	
Safety maximum ratings					
1) Case temperature	Tsi	$I_F=0,$ $P_C=0$	150	°C	Refer to the Fig. 3, 4 (Attachement-1-3)
2) Input current	Isi	$P_C=0$	200	mA	
3) Electric power (Output or Total power dissipation)	Psi	-	3600	mW	
Isolation resistance (Test voltage between input and output ; DC500V)	R_{ISO}	$T_{amb}=T_{si}$	MIN. 10^9	Ω	
		$T_{amb}=T_{opr}$ (MAX)	MIN. 10^{11}		
		$T_{amb}=25^\circ C$	MIN. 10^{12}		

- Precautions in performing isolation test

- 1) Partial discharge test methods shall be the ones according to the specifications of EN 60747-5-5.
- 2) Please don't carry out isolation test (Viso) over $V_{ini,a}$.

This product deteriorates isolation characteristics by partial discharge due to applying high voltage (ex. $V_{ini,a}$).
And there is possibility that partial discharge occurs in operating isolation voltage (V_{IORM}).

(Attachment-1-2)

●Pin-Number and internal connection diagram

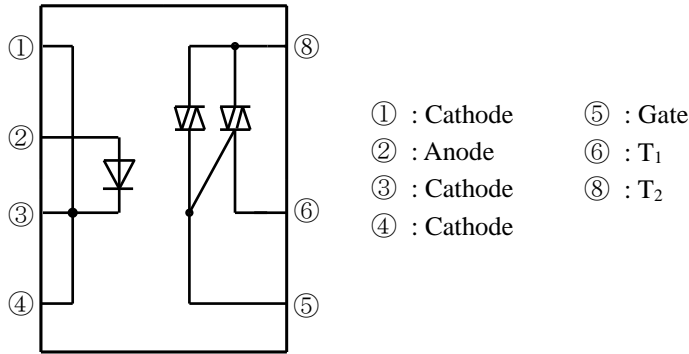

●Outline

Burr Max. 0.2
 Brand name "S"
 R3BMF5
 S
 Anode mark
 Factory identification mark *2
 Date code *1
 "L" identification mark
 Rank mark
 VDE identification mark
 Epoxy resin
 θ: 0~13°
 Product mass : Approx. 0.56g
 UNIT : 1/1 mm
 Name R3BMF5 Outline Dimensions (Business dealing name : PR3BMF51YSLF)

Marking is laser marking

*1) 2-digit number shall be marked according to OLD DIN standard.

*2) Factory identification mark applies to the below.

Without : SUN-S Corporation (Japan)

: SUN-S Electronic Technology (KUNSHAN) Co. Ltd (China)

*3) Pin material : Copper Alloy

Pin finish : SnCu plating (Cu : TYP. 2%)

(Attachment-1-3)

Method of Diagram 1: Breakdown test (Apply to type test and sampling test)

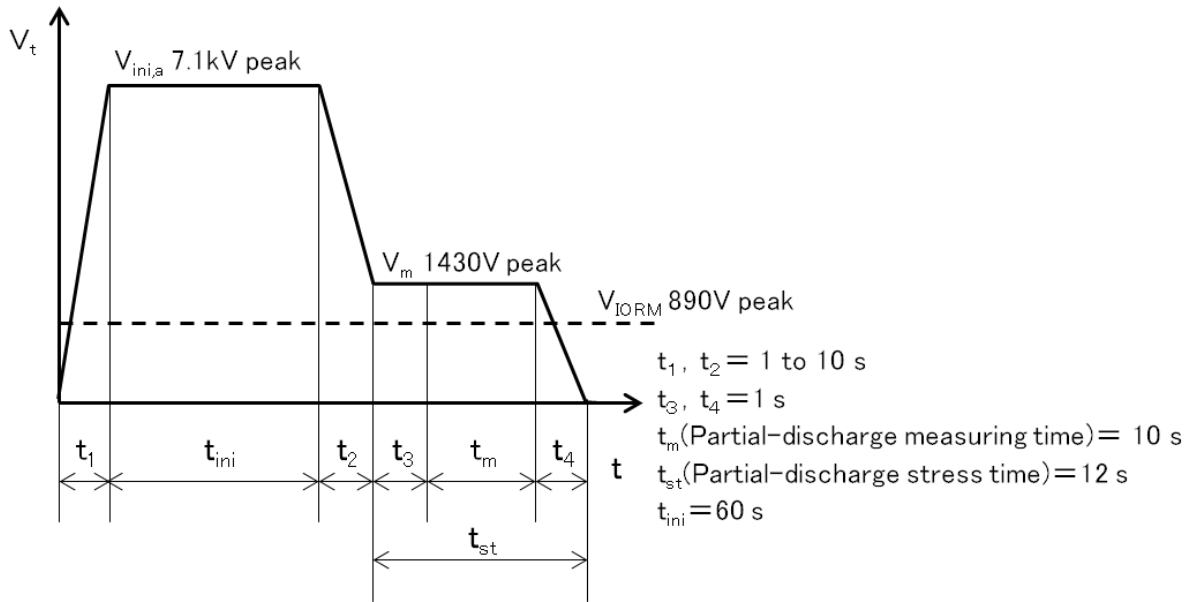

Method of Diagram 2: Non breakdown test (Apply to all device test)

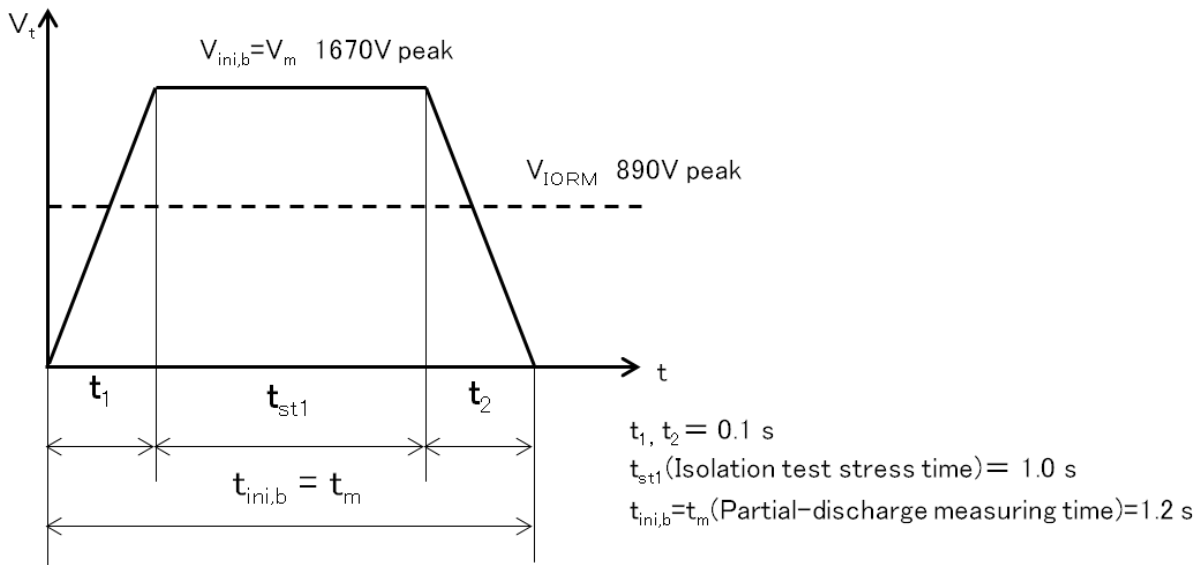

(Fig.3) Safety maximum power dissipation vs. ambient temperature (When failed)

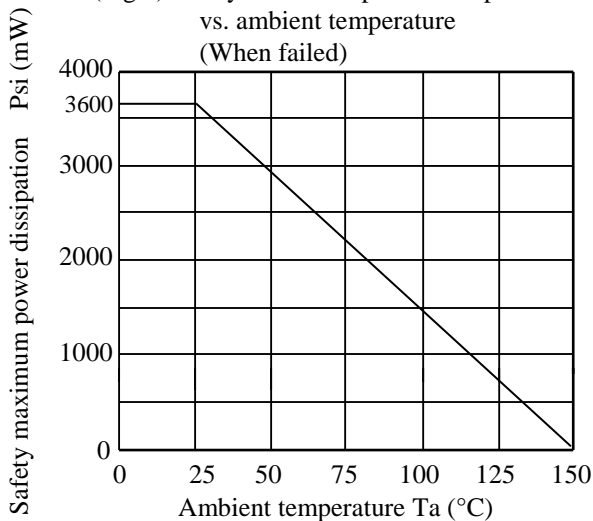

(Fig.4) Safety maximum forward current vs. ambient temperature (When failed)

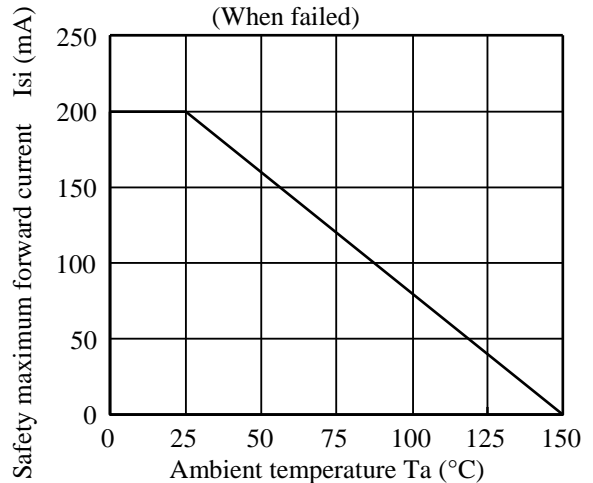

■ Important Notices

· The circuit application examples in this publication are provided to explain representative applications of SHARP devices and are not intended to guarantee any circuit design or license any intellectual property rights. SHARP takes no responsibility for any problems related to any intellectual property right of a third party resulting from the use of SHARP's devices.

· Contact SHARP in order to obtain the latest device specification sheets before using any SHARP device. SHARP reserves the right to make changes in the specifications, characteristics, data, materials, structure, and other contents described herein at any time without notice in order to improve design or reliability. Manufacturing locations are also subject to change without notice.

· Observe the following points when using any devices in this publication. SHARP takes no responsibility for damage caused by improper use of the devices which does not meet the conditions and absolute maximum ratings to be used specified in the relevant specification sheet nor meet the following conditions:

(i) The devices in this publication are designed for use in general electronic equipment designs such as:

- Personal computers
- Office automation equipment
- Telecommunication equipment [terminal]
- Test and measurement equipment
- Industrial control
- Audio visual equipment
- Consumer electronics

(ii) Measures such as fail-safe function and redundant design should be taken to ensure reliability and safety when SHARP devices are used for or in connection

with equipment that requires higher reliability such as:

- Transportation control and safety equipment (i.e., aircraft, trains, automobiles, etc.)
- Traffic signals
- Gas leakage sensor breakers
- Alarm equipment
- Various safety devices, etc.

(iii) SHARP devices shall not be used for or in connection with equipment that requires an extremely high level of reliability and safety such as:

- Space applications
- Telecommunication equipment [trunk lines]
- Nuclear power control equipment
- Medical and other life support equipment (e.g., scuba).

· If the SHARP devices listed in this publication fall within the scope of strategic products described in the Foreign Exchange and Foreign Trade Law of Japan, it is necessary to obtain approval to export such SHARP devices.

· This publication is the proprietary product of SHARP and is copyrighted, with all rights reserved. Under the copyright laws, no part of this publication may be reproduced or transmitted in any form or by any means, electronic or mechanical, for any purpose, in whole or in part, without the express written permission of SHARP. Express written permission is also required before any use of this publication may be made by a third party.

· Contact and consult with a SHARP representative if there are any questions about the contents of this publication.