

REVISION
SPEC. No. ED-04P078A
ISSUE September 14, 2005

SHARP

OPTO-ELECTRONIC DEVICES DIVISION
ELECTRONIC COMPONENTS GROUP
SHARP CORPORATION

SPECIFICATION

DEVICE SPECIFICATION FOR
PHOTOTRIAC COUPLER
MODEL No.
3SD12

Business dealing name

	PC3SD12NTZAF
	PC3SD12YTZAF

Specified for _____

Enclosed please find copies of the Specifications which consists of 14 pages including cover.
This specification sheets and attached sheets shall be both side copy.
After confirmation of the contents, please be sure to send back copies of the Specifications
with approving signature on each.

CUSTOMER'S APPROVAL

PRESENTED

DATE

DATE

BY

BY *H. Imanaka*

H. Imanaka,
Department General Manager of
Engineering Dept.,II
Opto-Electronic Devices Div.
ELECOM Group
SHARP CORPORATION

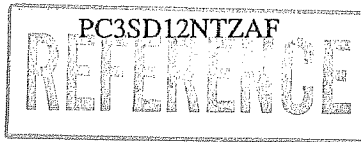

Product name : PHOTOTRIAC COUPLER

Model No. : 3SD12

(Business dealing name : PC3SD12NTZAF)

(Business dealing name : PC3SD12YTZAF)

1. These specification sheets include materials protected under copyright of Sharp Corporation ("Sharp"). Please do not reproduce or cause anyone to reproduce them without Sharp's consent.
2. When using this product, please observe the absolute maximum ratings and the instructions for use outlined in these specification sheets, as well as the precautions mentioned below. Sharp assumes no responsibility for any damage resulting from use of the product which does not comply with the absolute maximum ratings and the instructions included in these specification sheets, and the precautions mentioned below.

(Precautions)

- (1) This product is designed for use in the following application areas ;

[· OA equipment · Audio visual equipment · Home appliances
· Telecommunication equipment (Terminal) · Measuring equipment
· Tooling machines · Computers]

If the use of the product in the above application areas is for equipment listed in paragraphs (2) or (3), please be sure to observe the precautions given in those respective paragraphs.

- (2) Appropriate measures, such as fail-safe design and redundant design considering the safety design of the overall system and equipment, should be taken to ensure reliability and safety when this product is used for equipment which demands high reliability and safety in function and precision, such as ;

[· Transportation control and safety equipment (aircraft, train, automobile etc.)
· Traffic signals · Gas leakage sensor breakers · Rescue and security equipment
· Other safety equipment]

- (3) Please do not use this product for equipment which require extremely high reliability and safety in function and precision, such as ;

[· Space equipment · Telecommunication equipment (for trunk lines)
· Nuclear power control equipment · Medical equipment]

- (4) Please contact and consult with a Sharp sales representative if there are any questions regarding interpretation of the above three paragraphs.

3. Please contact and consult with a Sharp sales representative for any questions about this product.



1. Application

This specification applies to the outline and characteristics of phototriac coupler Model No. 3SD21 (Apply line voltage 200V AC).

2. Outline

Refer to the attached sheet, page 4.

3. Ratings and characteristics

Refer to the attached sheet, page 5, 6.

4. Reliability

Refer to the attached sheet, page 7.

5. Outgoing inspection

Refer to the attached sheet, page 8.

6. Supplement

6.1 Business dealing name

("O" mark indicates business dealing name of ordered product)

Product	Business dealing name	Remarks
	PC3SD12NTZAF	
	PC3SD12YTZAF	* Applied to products as an option (Attachment-1-1 to 1-3)

6.2 Package specification

Refer to the attached sheet, page 9,10.

6.3 Isolation voltage shall be measured in the following method.

- (1) Short between pins 1 to 3 on the primary side and between pins 4 to 6 on the secondary side.
- (2) The dielectric withstanding tester with zero-cross circuit shall be used.
- (3) The wave form of applied voltage shall be a sine wave.

(It is recommended that the isolation voltage be measured in insulation oil.)

6.4 This Model is approved by UL and CSA.

Approved Model No. : 3SD12

UL file No. : E64380

CSA file No. : CA95323

CSA approved mark "  " shall be indicated on minimum unit package.

6.5 This product is not designed against irradiation.

This product is assembled with electrical input and output.

This product incorporates non-coherent light emitting diode.

6.6 ODS materials

This product shall not contain the following materials.

Also, the following materials shall not be used in the production process for this product.

Materials for ODS : CFCs, Halon, Carbon tetrachloride,

1.1.1-Trichloroethane (Methyl chloroform)

6.7 Brominated flame retardants

Specific brominated flame retardants such as the PBBO₅ and PBB₅ are not used in this device at all.

7. Notes

7.1 Circuit design

- (1) The LED used in the Phototriac coupler generally decreases the light emission power by operation.
 In case of long operation time, please decide I_F value so that I_F is more than 2 times of the Maximum value of the Minimum triggering current at circuit design with considering the decreases of the light emission power of the LED. (50% / 5years)
- (2) Input current (I_F) at off state shall be set 0.1mA or less.
- (3) In case that pulse drive is carried out, the pulse width of input signal should be 1ms or more.

7.2 Usage

For triggering medium and high power triac.
 (This model shall be used under the conditions on which power triac turns on.)

7.3 Cleaning

- (1) Solvent cleaning : Solvent temperature 45°C or less, Immersion for 3 min or less
- (2) Ultrasonic cleaning : The effect to device by ultrasonic cleaning differs by cleaning bath size, ultrasonic power output, cleaning time, PCB size or device mounting condition etc.
 Please test it in actual using condition and confirm that any defect doesn't occur before starting the ultrasonic cleaning.
- (3) Applicable solvent : Ethyl alcohol, Methyl alcohol, Isopropyl alcohol
 When the other solvent is used, there are cases that the packaging resin is eroded.
 Please use the other solvent after thorough confirmation is performed in actual using condition.

7.4 Precautions for Soldering Phototriac couplers

- (1) In case of flow solder (Whole dipping is possible)
 It is recommended that flow soldering be carried out at 270°C or less and within 10s
 (Pre-heating : 100 to 150°C, 30 to 80s) : Within 2 times
- (2) It is recommended that hand soldering be carried out at 400°C or less and within 3s: Within 2 times
- (3) Other notes
 Depending on equipment and soldering conditions (temperature, Using solder etc.), the effect to junction between PCB and lead pins of photocoupler is different.
 Please confirm that there is no problem on the actual use conditions.

PC3SD12NTZAF
REFERENCE

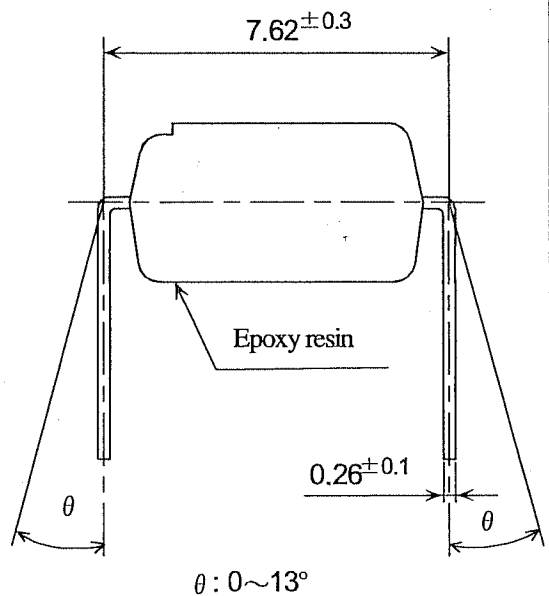
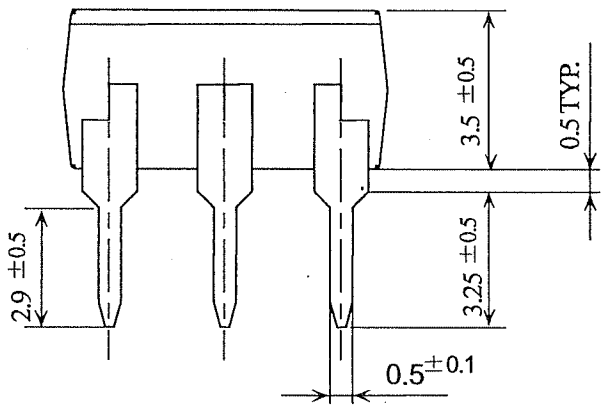
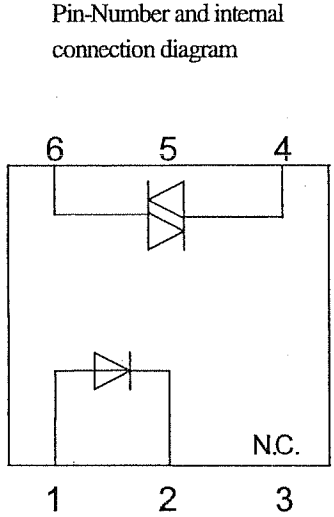
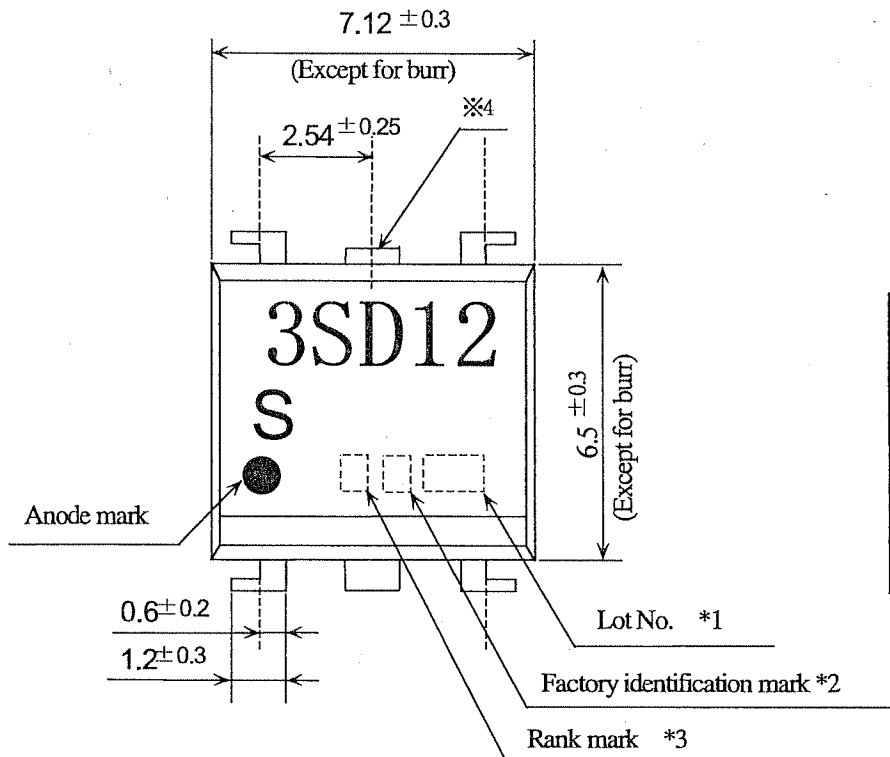

- *1) 2-digit number shall be marked according to OLD DIN standard.
- *2) Factory identification mark applies to the below.
Without : SUN-S Corporation(Japan)
 : SUN-S Electronic Technology (KUNSHAN) Co. Ltd (China)
- *3) Rank mark : "A"
- *4) Any external connection with Pin 5 is not allowable.
Pin 5 is cut at outside of package.
- *5) Pin material : Copper Alloy
Pin finish : SnCu plating (Cu : TYP. 2%)

Product mass : Approx.0.35g

Unit : 1/1mm

Name	3SD12 Outline Dimensions (Business dealing name : PC3SD12NTZAF)
------	---

3.1 Absolute maximum ratings

Ta=25°C

Parameter		Symbol	Rating	Unit
Input	Forward current *1	I _F	50	mA
	Reverse voltage	V _R	6	V
Output	RMS on-state current *1	I _{T(rms)}	0.1	A
	Peak one cycle surge current	I _{surge}	1.2 (50Hz sine wave)	A
	Repetitive peak off-state voltage	V _{DRM}	600	V
Isolation voltage *2		V _{iso(rms)}	5	kV
Operating temperature		T _{opr}	-30 to +100	°C
Storage temperature		T _{stg}	-55 to +125	°C
Soldering temperature		T _{sol}	270 (For 10s)	°C

*1 The derating factors of absolute maximum rating due to ambient temperature are shown in Fig.1, 2.

*2 AC for 1min, 40 to 60%RH, f=60Hz

3.2 Electrical characteristics

Ta=25°C

Parameter		Symbol	MIN.	TYP.	MAX.	Unit	Conditions
Input	Forward voltage	V _F	-	1.2	1.4	V	I _F =20mA
	Reverse current	I _R	-	-	10 ⁻⁵	A	V _R =3V
Output	Repetitive peak off-state current	I _{DRM}	-	-	10 ⁻⁶	A	V _D =V _{DRM}
	On-state voltage	V _T	-	-	2.5	V	I _T =0.1A
	Holding current	I _H	0.1	-	3.5	mA	V _D =6V
	Critical rate of rise of off-state voltage	dv/dt	1000	2000	-	V/μs	V _D =1/√2 · V _{DRM}
Transfer characteristics	Minimum trigger current	I _{FT}	-	-	10	mA	V _D =6V, R _L =100Ω
	Isolation resistance	R _{ISO}	5 × 10 ¹⁰	10 ¹¹	-	Ω	DC500V 40 to 60%RH
	Turn on time	t _{ON}	-	-	50	μs	V _D =6V, R _L =100Ω, I _F =20mA

Fig.1 Forward current vs. ambient temperature

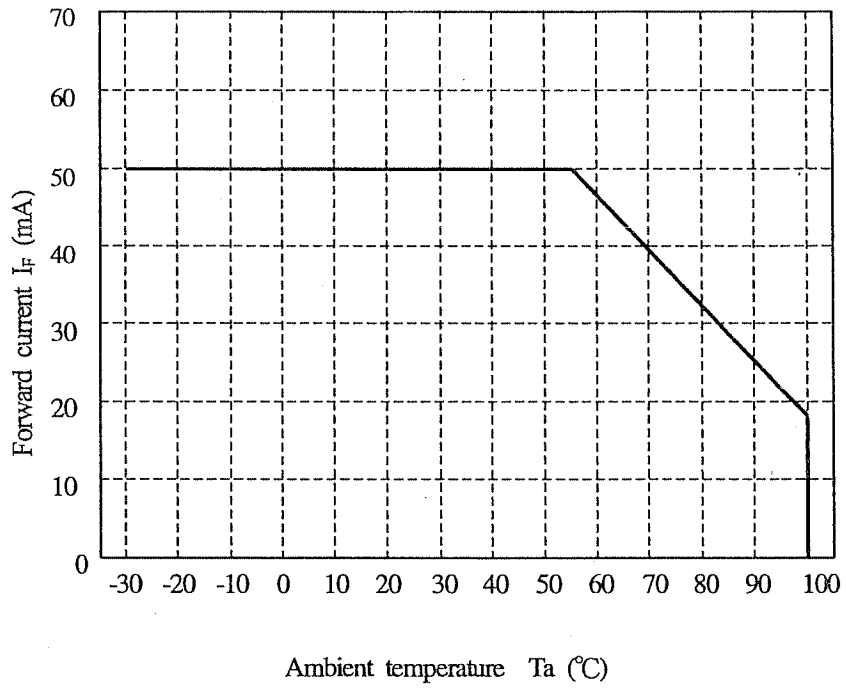
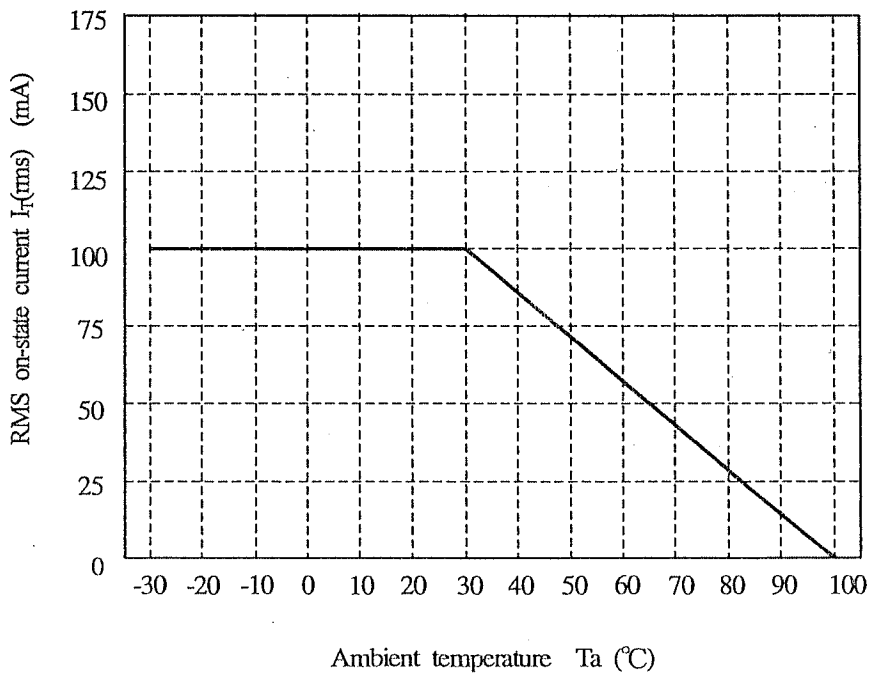

Fig.2 RMS on-state current vs. ambient temperature



4. Reliability

The reliability of products shall satisfy items listed below.

Confidence level : 90%

LTPD : 10 or 20

Test Items	Test Conditions *1	Failure Judgement Criteria	Samples (n)
			Defective(C)
Solderability *2	245±3°C, 5s	—	n=11, C=0
Soldering heat *3	(Flow soldering) 270°C, 10 s	$V_F > U \times 1.2$ $V_T > U \times 1.2$ $I_{FT} > U \times 1.3$ $I_R > U \times 2.0$ $I_{DRM} > U \times 2.0$ U : Upper specification limit L : Lower specification limit	n=11, C=0
	(Soldering by hand) 400°C, 3 s		n=11, C=0
Terminal strength (Tension)	Weight : 5.0N		n=11, C=0
	5 s/each terminal		n=11, C=0
Terminal strength (Bending) *4	Weight : 2.5N		n=11, C=0
	2 times/each terminal		n=11, C=0
Mechanical shock	15km/s ² , 0.5ms		n=11, C=0
	3 times/±X, ±Y, ±Z direction		n=11, C=0
Variable frequency vibration	100 to 2000 to 100Hz/4min		n=11, C=0
	200m/s ² 4 times/ X, Y, Z direction		n=11, C=0
Temperature cycling	1 cycle -55°C to +125°C	n=22, C=0	
	(30min) (30min) 20 cycles test Without Load	n=22, C=0	
High temp. and high humidity storage	+85°C, 85%RH, 500h	n=22, C=0	
High temp. storage	+125°C, 1000h	n=22, C=0	
Low temp. storage	-55°C, 1000h	n=22, C=0	
Operation life	I _F =50mA, I _T =100mA T _a =25°C, 1000h	n=22, C=0	

- *1 Test method, conforms to EIAJ ED 4701.
- *2 Solder shall adhere at the area of 95% or more of immersed portion of lead, and pin hole or other holes shall not be concentrated on one portion.
- *3 Dip into the position of 1.0mm from the resin part.
- *4 Terminal bending direction is shown below.

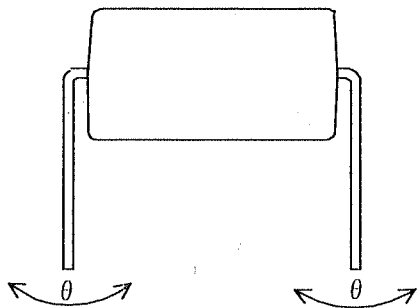

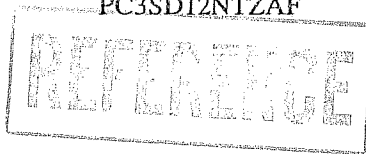

5. Outgoing inspection

5.1 Inspection items

(1) Electrical characteristics

V_F , I_R , I_{DRM} , V_T , I_{FT} , R_{ISO} , V_{ISO}

(2) Appearance

5.2 Sampling method and Inspection level

A single sampling plan, normal inspection level II based on ISO 2859 is applied.

The AQL according to the inspection items are shown below.

Defect	Inspection item	AQL (%)
Major defect	Electrical characteristics Unreadable marking	0.065
Minor defect	Appearance defect except the above mentioned.	0.25

6.2 Package specification

6.2.1 Package materials

No.	Name	Materials	Purposes
1	Sleeve	HIPS with preventing static electricity	Products packaged
2	Stopper	Styrene-Elastomer	Products fixed
3	Packing case	Corrugated cardboard	Sleeve packaged
4	Kraft tape	Paper	Lid of packaged case fixed
5	Label	Paper	Model No.(Business dealing name), lot No. , quantity , country of origin , Company name and inspection date specified

6.2.2 Package method

- (1) MAX. 50pcs. of products shall be packaged in a sleeve and both of sleeve edges shall be fixed by stoppers.
- (2) MAX. 20 sleeves above shall be packaged in a packing case and pack a sheet of cushion at one side.
- (3) The label shall be put on the side of the packaging case.
- (4) Case shall be closed with the lid and enclosed with kraft tape.

6.2.3. Sleeve drawing

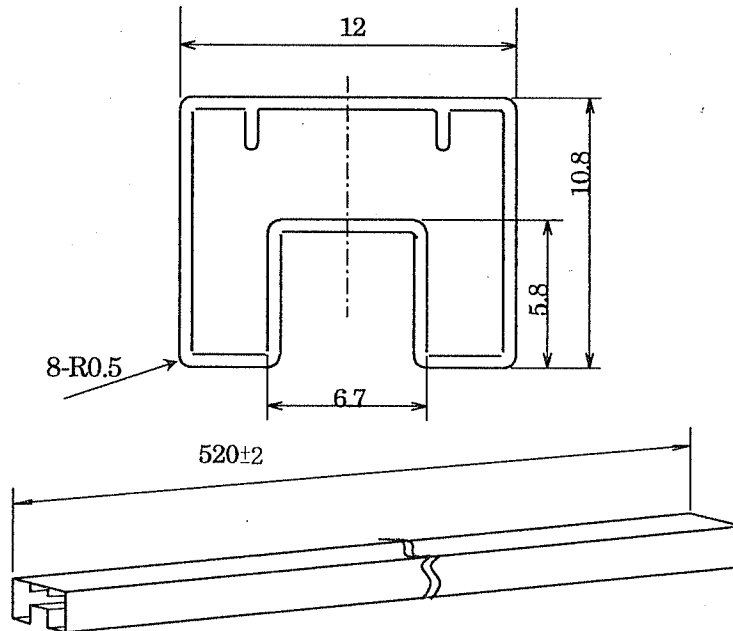

(Unit : mm)

Length : L=520 ± 2mm

- Note 1) Thickness : 0.5 ± 0.2 mm
 2) Process with applying antistatic treatment.
 3) Unless otherwise specified tolerances shall be ± 0.5 mm.
 (However except for deformation due to the rubber stopper in sleeve.)

6.2.4. Packing case outline dimensions

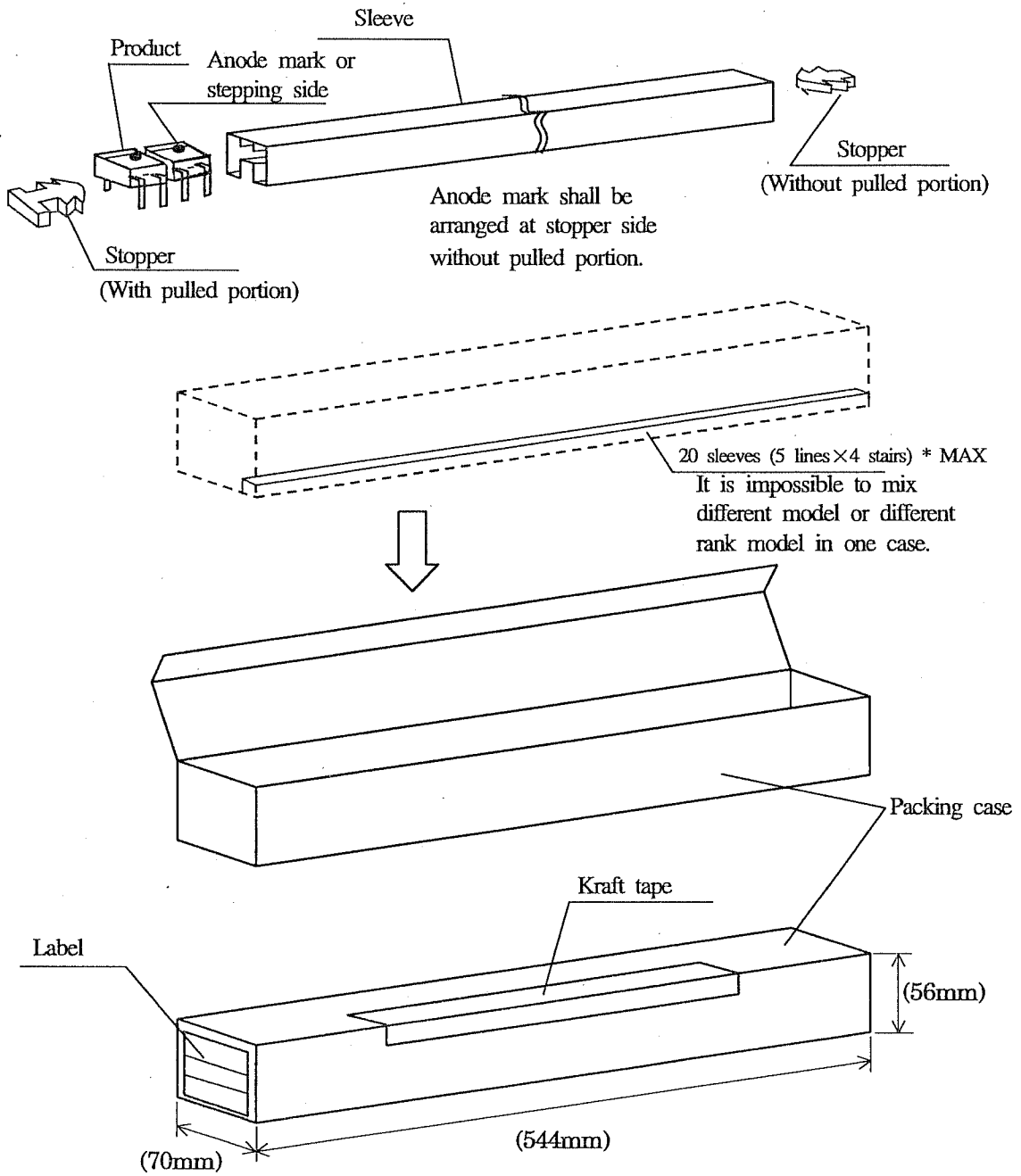

Regular packing mass : Approx. 760g

() : Reference dimensions

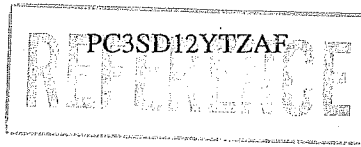

1. This specification shall be applied to photocoupler, Model No. 3SD12 series as an option.

2. Applicable Models (Business dealing name)

PC3SD12YTZAF

3. The relevant models are the models Approved by VDE according to DIN EN 60747-5-2.

Up to date code "RD" (December 2003), the relevant models are approved by VDE according to DIN VDE 0884/08.87.

Approved Model No. : 3SD12

VDE approved No. : 40008189 (According to the specification DIN EN 60747-5-2)

- Operating isolation voltage $U_{IORM(PEAK)}$: 890V
- Transient voltage : 9000V
- Pollution : 2
- Clearances distance (Between input and output): 6.4 mm (MIN.)
- Creepage distance (Between input and output): 6.4 mm (MIN.)
- Isolation thickness between input and output : 0.15 mm (MIN.)
- Tracking-proof : CTI 175
- Safety limit values
 - Current (Isi) : 200mA (Diode side)
 - Power (Psi) : 400mW (Phototransistor side)
 - Temperature (Tsi) : 150°C

In order to keep safety electric isolation of photocoupler, please set the protective circuit to keep within safety limit values when the actual application equipment troubled.

- Indication of VDE approval "  " is printed on the minimum packing box.

4. Outline

Refer to the attachment-1-2.

5. Isolation specification according to EN 60747-5-2.

Parameter	Symbol	Conditions	Rating	Unit	Remark				
Class of environmental test	-	DIN IEC68	40/100/21	-	Refer to the Diagram 1, 2 (Attachment -1-3)				
Pollution	-	DIN VDE0110	2	-					
Maximum operating isolation voltage	$U_{IORM(PEAK)}$	-	890	V					
Partial discharge test voltage (Between input and output)	Diagram 1	$U_{PI(PEAK)}$	tp=10 s, qc<5pC	1340		V			
	Diagram 2						tp=1 s, qc<5pC	1670	V
Maximum over-voltage	$U_{IOTM(PEAK)}$	$t_{NI}=60$ s	9000	V					
Safety maximum ratings									
1) Case temperature	Tsi	$I_F=0, P_c=0$	150	°C	Refer to Fig.1, 2 (Attachment -1-3)				
2) Input current	Isi	$P_c=0$	200	mA					
3) Electric power (Output or Total power dissipation)	Psi	-	400	mW					
Isolation resistance (Test voltage between input and output ; DC 500V)	R_{ISO}	Ta=Tsi	MIN. 10^9	Ω					
		Ta=Topr (MAX.)	MIN. 10^{11}						
		Ta=25°C	MIN. 10^{12}						

6. Precautions in performing isolation test

6.1 Partial discharge test methods shall be the ones according to the specifications of EN 60747-5-2

6.2 Please don't carry out isolation test (V_{ISO}) over U_{IOTM} . This product deteriorates isolation characteristics by partial discharge due to applying high voltage (ex. U_{IOTM}). And there is possibility that partial discharge occurs in operating isolation voltage. (U_{IORM}).

PC3SD12YTZAF
REFERENCE

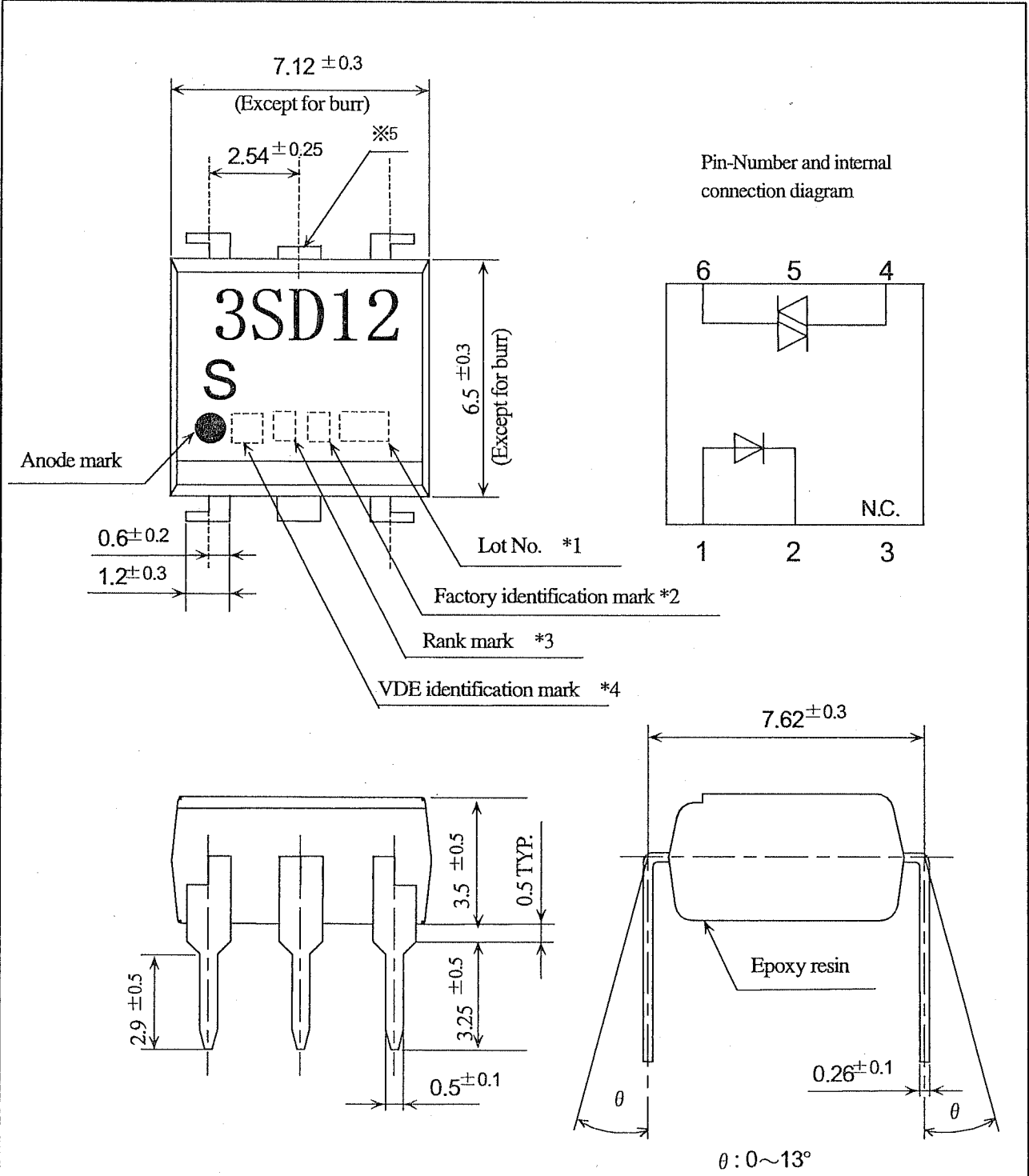

- *1) 2-digit number shall be marked according to OLD DIN standard.
- *2) Factory identification mark applies to the below.
 Without : SUN-S Corporation(Japan)
 : SUN-S Electronic Technology (KUNSHAN) Co. Ltd (China)
- *3) Rank mark : "A"
- *4) VDE identification mark shall be marked "4".
- *5) Any external connection with Pin 5 is not allowable.
 Pin 5 is cut at outside of package.
- *6) Pin material : Copper Alloy
 Pin finish : SnCu plating (Cu : TYP. 2%)

Product mass : Approx.0.35g

UNIT : 1/1 mm	
Name	3SD12 Outline Dimensions (Business dealing name : PC3SD12YTZAF)

Method of Diagram 1: Breakdown test (Apply to type test and sampling test)

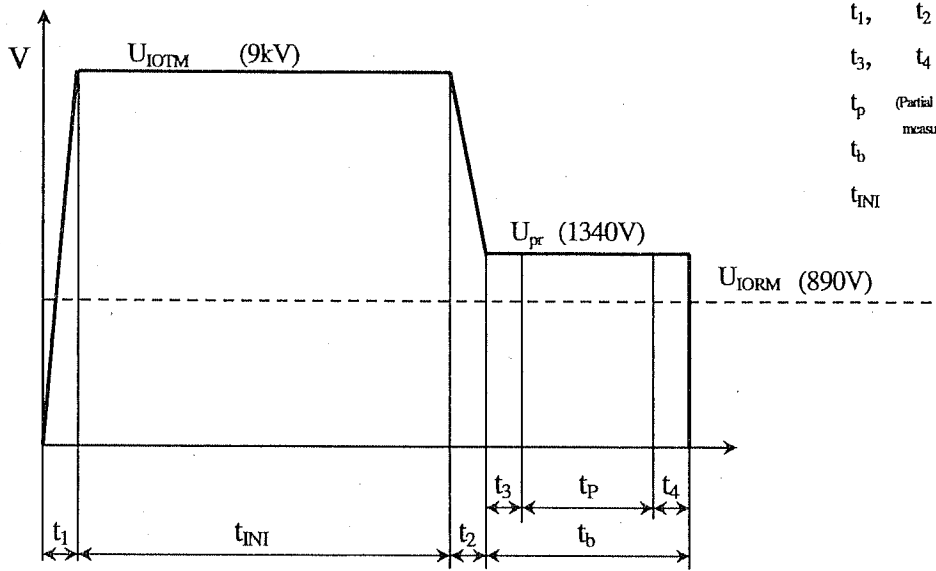

- t_1, t_2 = 1 to 10 s
- t_3, t_4 = 1 s
- t_p (Partial discharge measuring time) = 10 s
- t_b = 12 s
- t_{INI} = 60 s

Method of Diagram 2 : Non breakdown test (Apply to all device test)

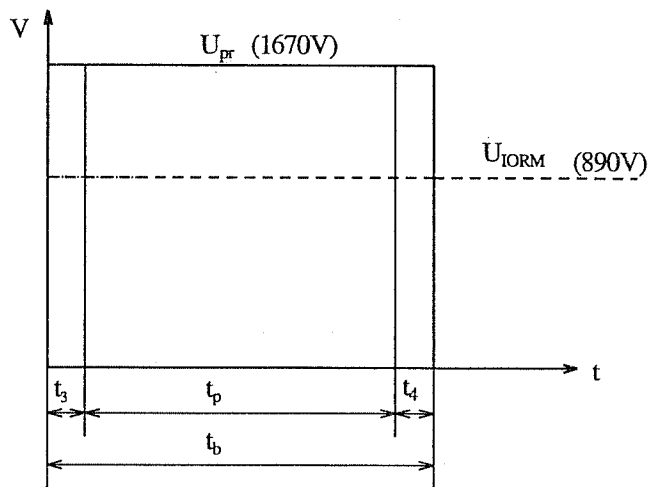

- t_3, t_4 = 0.1 s
- t_p (Partial discharge measuring time) = 1 s
- t_b = 1.2 s

Fig. 1 Safety maximum power dissipation vs. ambient temperature (When failed)

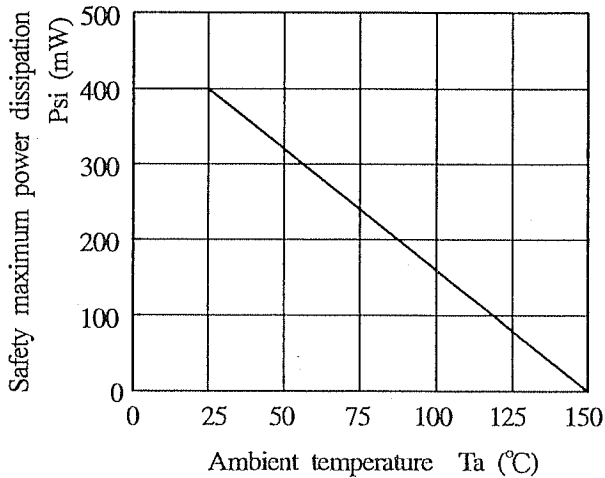

Fig. 2 Safety maximum forward current vs. ambient temperature (When failed)

