

**REFERENCE**  
SPEC. No. ED-05C159  
ISSUE July 8, 2005

**SHARP**

OPTO-ELECTRONIC DEVICES DIVISION  
ELECTRONIC COMPONENTS GROUP  
SHARP CORPORATION

**SPECIFICATION**

DEVICE SPECIFICATION FOR  
PHOTOTRANSISTOR  
MODEL No. PT480E00000F

Specified for \_\_\_\_\_

Enclosed please find copies of the Specifications which consists of 9 pages including cover.  
After confirmation of the contents, please be sure to send back  copy of the Specifications  
with approving signature on each.

CUSTOMER'S APPROVAL

DATE  
\_\_\_\_\_

BY  
\_\_\_\_\_

PRESENTED

DATE  
\_\_\_\_\_

BY 19 0  
\_\_\_\_\_

H. Ogura,  
Department General Manager of  
Engineering Dept., III  
Opto-Electronic Devices Div.  
ELECOM Group  
SHARP CORPORATION

Product name : PHOTOTRANSISTOR

Model No. : PT480E00000F

1. These specification sheets include materials protected under copyright of Sharp Corporation ("Sharp"). Please do not reproduce or cause anyone to reproduce them without Sharp's consent.
2. When using this product, please observe the absolute maximum ratings and the instructions for use outlined in these specification sheets, as well as the precautions mentioned below. Sharp assumes no responsibility for any damage resulting from use of the product which does not comply with the absolute maximum ratings and the instructions included in these specification sheets, and the precautions mentioned below.

(Precautions)

- (1) This product is designed for use in the following application areas ;  
(
  - OA equipment · Audio visual equipment · Home appliances
  - Telecommunication equipment (Terminal) · Measuring equipment
  - Tooling machines · Computers)  
If the use of the product in the above application areas is for equipment listed in paragraphs (2) or (3), please be sure to observe the precautions given in those respective paragraphs.

- (2) Appropriate measures, such as fail-safe design and redundant design considering the safety design of the overall system and equipment, should be taken to ensure reliability and safety when this product is used for equipment which demands high reliability and safety in function and precision, such as ;  
(
  - Transportation control and safety equipment (aircraft, train, automobile etc.)
  - Traffic signals · Gas leakage sensor breakers · Rescue and security equipment
  - Other safety equipment)

- (3) Please do not use this product for equipment which require extremely high reliability and safety in function and precision, such as ;  
(
  - Space equipment · Telecommunication equipment (for trunk lines)
  - Nuclear power control equipment · Medical equipment)

- (4) Please contact and consult with a Sharp sales representative if there are any questions regarding interpretation of the above three paragraphs.

3. Please contact and consult with a Sharp sales representative for any questions about this product.



1. Application

This specification applies to the outline and characteristics of Silicon phototransistor Model No. PT480E00000F.

2. Outline

Refer to the attached drawing No. CY13108H02 ,page 3.

3. Ratings and characteristics

Refer to the attached sheet, page 4, 5.

4. Reliability

Refer to the attached sheet, page 6.

5. Outgoing inspection

Refer to the attached sheet, page 7.

6. Supplement

(6-1) Packing

Refer to the attached sheet, page 8.

(6-2) This product is not designed against electromagnetic and ionized-particle irradiation.

(6-3) This product shall not contain the following materials.

Also, the following materials shall not be used in the production process for this product.

Materials for ODS : CFC<sub>s</sub>, Halon, Carbon tetrachloride

1,1,1-Trichloroethane (Methyl chloroform)

(6-4) This product does not contain the chemical materials regulated by RoHS.

(6-5) This product does not contain specific brominated flame retardants such as the PBBO<sub>s</sub> and PBB<sub>s</sub>.

(6-6) Product mass (Piece) : Approximately 0.09g

7. Notes

(7-1) Cleaning conditions :

Solvent cleaning : Solvent temperature 45°C or less Immersion for 3 min or less

Ultrasonic cleaning : The effect to device by ultrasonic cleaning differs by cleaning bath size, ultrasonic power output, cleaning time, PCB size or device mounting condition etc.

Please test it in actual using condition and confirm that doesn't occur any defect before starting the ultrasonic cleaning.

The cleaning shall be carried out with solvent below.

Solvent : Ethyl alcohol, Methyl alcohol, Isopropyl alcohol

(7-2) Soldering

The lead pins should be soldered according to the absolute maximum ratings.

While or after soldering, the lead pins shall be free from external force.

This device shall not be soldered with preheat or reflow.

The terminal covering of this device consists of lead free solder.

In case of mounting this device in a lead free soldering process, special care should be taken to avoid

any boundary exfoliation (Lift-off phenomenon) between the solder and the solder pad on the printed circuit board.

# REFERENCE

SHARP

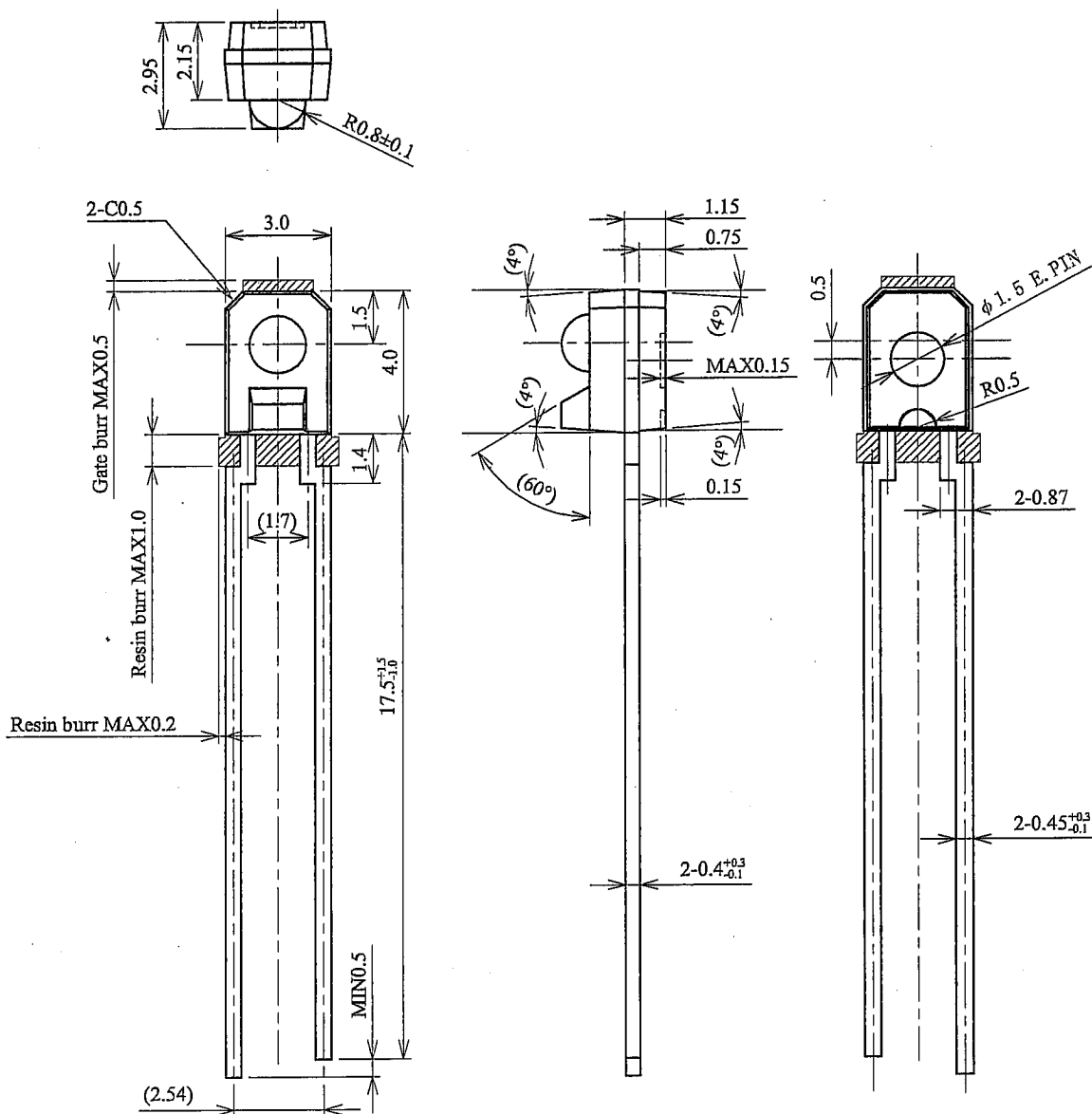

- 1) Unspecified tolerance shall be  $\pm 0.2$ .
- 2) Package : Transparent
- 3) Dimensions in parenthesis are shown for reference.
- 4) The thin burr thickness (MAX. 0.05mm) and the gate burr (MAX. 0.5mm) shall not be inclusive to the outline dimensions.
- 5) Protruded resin 1.0mm MAX. However, the thin burr with a lead attached is 1.4mm MAX. from the resin.

Pin name

Terminal connection

- ① Emitter
- ② Collector



Scale	Material	Finish	Name	PT480E00000F Outline Dimensions									
5 / 1													
Unit	Lead : Fe	Lead pin: Solder dip	Drawing No.	C	Y	1	3	1	0	7	H	0	2
1 = 1 / 1 mm	Package : Epoxy resin	Lead-free solder use Composition(Standard value) Sn96.5%,Ag3.0%,Cu0.5%											

### 3. Ratings and characteristics

#### 3.1 Absolute maximum ratings

Ta=25°C

Parameter	Symbol	Rating	Unit
Collector-emitter voltage	V <sub>CEO</sub>	35	V
Emitter-collector voltage	V <sub>ECO</sub>	6	V
Collector current	I <sub>C</sub>	20	mA
Collector power dissipation	P <sub>C</sub>	75	mW
Operating temperature	T <sub>opr</sub>	-25 to +85	°C
Storage temperature	T <sub>Stg</sub>	-40 to +85	°C
* Soldering temperature	T <sub>Sol</sub>	260	°C

\* For 5 seconds MAX. at the position of 1.4mm from the resin edge.

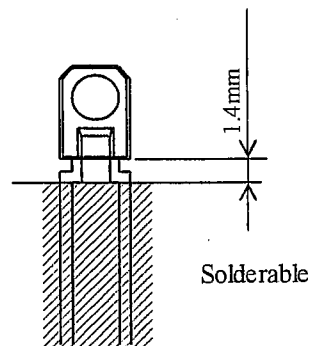

#### 3.2 Electro-optical characteristics

Ta=25°C

Parameter	Symbol	MIN.	TYP.	MAX.	Unit	Conditions
Collector current	I <sub>C</sub>	0.4	1.7	6.0	mA	※E <sub>e</sub> =1mW/cm <sup>2</sup> V <sub>CE</sub> =5V
Dark current	I <sub>CBO</sub>	-	1.0	100	nA	E <sub>e</sub> =0, V <sub>CE</sub> =20V
Collector-emitter saturation voltage	V <sub>CE(sat)</sub>	-	0.1	0.4	V	※E <sub>e</sub> =10mW/cm <sup>2</sup> I <sub>C</sub> =0.5mA
Collector-emitter breakdown voltage	BV <sub>CEO</sub>	35	-	-	V	I <sub>C</sub> =0.1mA E <sub>e</sub> =0
Emitter-collector breakdown voltage	BV <sub>ECO</sub>	6	-	-	V	I <sub>E</sub> =0.01mA E <sub>e</sub> =0
Peak sensitivity wavelength	λ <sub>p</sub>	-	800	-	nm	-
Response time (Rise)	t <sub>r</sub>	-	3.0	-	μs	V <sub>CE</sub> =2V, I <sub>C</sub> =2mA R <sub>L</sub> =100Ω
Response time (Fall)	t <sub>f</sub>	-	3.5	-	μs	

※ E<sub>e</sub> : Irradiance by CIE standard light source A (tungsten lamp)

(3.3) Collector power dissipation vs. ambient temperature

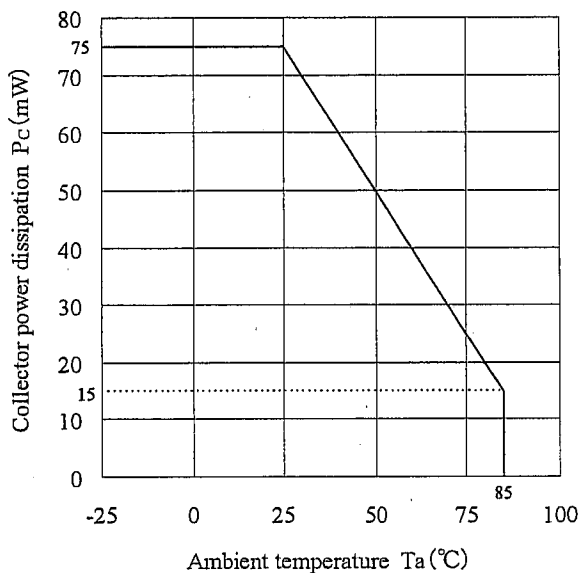

(3.4) Spectral sensitivity (reference)

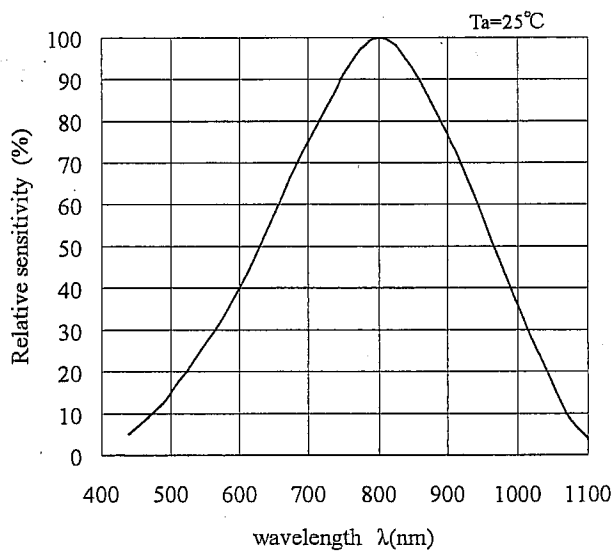

#### 4. Reliability

The reliability of products shall satisfy items listed below.

Confidence level : 90%

LTPD : 10 or 20

Test Items	Test Conditions	Failure Judgement Criteria	Samples (n)
			Defective(C)
Temperature cycling	1 cycle $-40^{\circ}\text{C} \longleftrightarrow +85^{\circ}\text{C}$ (30min) (30min) 20 cycles test	$I_C < L \times 0.8$ $I_C > U \times 1.2$ $I_{CEO} > U \times 2.0$ $V_{CE(sat)} > U \times 1.2$  U: Upper specification limit L: Lower specification limit	n=22, C=0
High temp. and high humidity storage	+60°C, 90%RH, 500h		n=22, C=0
High temp. storage	+85°C, 500h		n=22, C=0
Low temp. storage	-40°C, 500h		n=22, C=0
Operation life	$P_C=75\text{mW}$ , $T_a=25^{\circ}\text{C}$ , 500h		n=22, C=0
Mechanical shock	1000m/s <sup>2</sup> , 6ms, Half sine wave 3 times/ $\pm X$ , $\pm Y$ , $\pm Z$ direction		n=11, C=0
Variable frequency vibration	100 to 2000 to 100Hz/Sweep for 4min 200m/s <sup>2</sup> , 48min/ $X$ , $Y$ , $Z$ direction		n=11, C=0
Terminal strength (Tension)	Weight: 5N 10 s/each terminal		n=11, C=0
Terminal strength (Bending)	Weight: 2.5N $0^{\circ} \rightarrow 90^{\circ} \rightarrow 0^{\circ} \rightarrow -90^{\circ} \rightarrow 0^{\circ}$ The one test should be performed.		n=11, C=0
Soldering heat	$260 \pm 5^{\circ}\text{C}$ , $5 \pm 0.5\text{s}$ Position of 1.4mm from the resin edge.		n=11, C=0
Solderability	$245 \pm 5^{\circ}\text{C}$ , $5 \pm 1\text{s}$ Position of 1.4mm from the resin edge. Flux: EC-19S (Tamura kaken corporation) No pretreatment	Solder shall adhere at less than 95% area of dipped portion.	n=11, C=0

## 5. Outgoing inspection

## (1) Inspection lot

Inspection shall be carried out per each delivery lot.

## (2) Inspection method

A single sampling plan, normal inspection level II based on ISO2859 shall be adopted.

Defect	Inspection items and test method				AQL(%)		
Major defect	1	Disconnection, short				0.065	
	2	Inverse polarity on terminal					
	3	Characteristics defect					
		Parameter	Symbol	Judgement criteria			Unit
				MIN.	MAX.		
		Collector current	$I_C$	1.5	25		mA
		Dark current	$I_{CEO}$	-	1000		nA
	Collector-emitter breakdown voltage	$BV_{CEO}$	35	-	V		
	Emitter-collector breakdown voltage	$BV_{ECO}$	6.0	-	V		
	Test conditions refer to paragraph 3.2.						
Minor defect	1	Appearance defect				0.25	
		Parameter	Judgement criteria				
		Crack	Visible crack irrespective of its position shall be defect.				
		Split, Chip, Scratch, Stain, Blur	One which affects the characteristics of paragraph 3.2. shall be defect.				
	Bubble, Foreign matter (One on resin surface which can wipe off shall not be applied.)	1. On light detector 0.4mm $\phi$ or more shall be defect. 2. Area excepting on light detector 1.0mm $\phi$ or more shall be defect.					



## 6-1 Packaging

### 6-1-1 Inner packing

#### ① Inner packing drawing

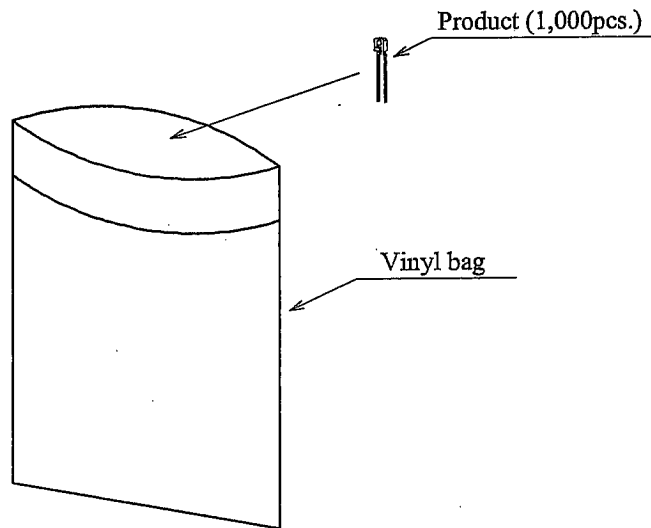

② Inner packing material : Vinyl bag (Polyethylene)

③ Quantity : 1,000pcs./bag

### 6-1-2 Outer packing

#### ① Outer packing drawing

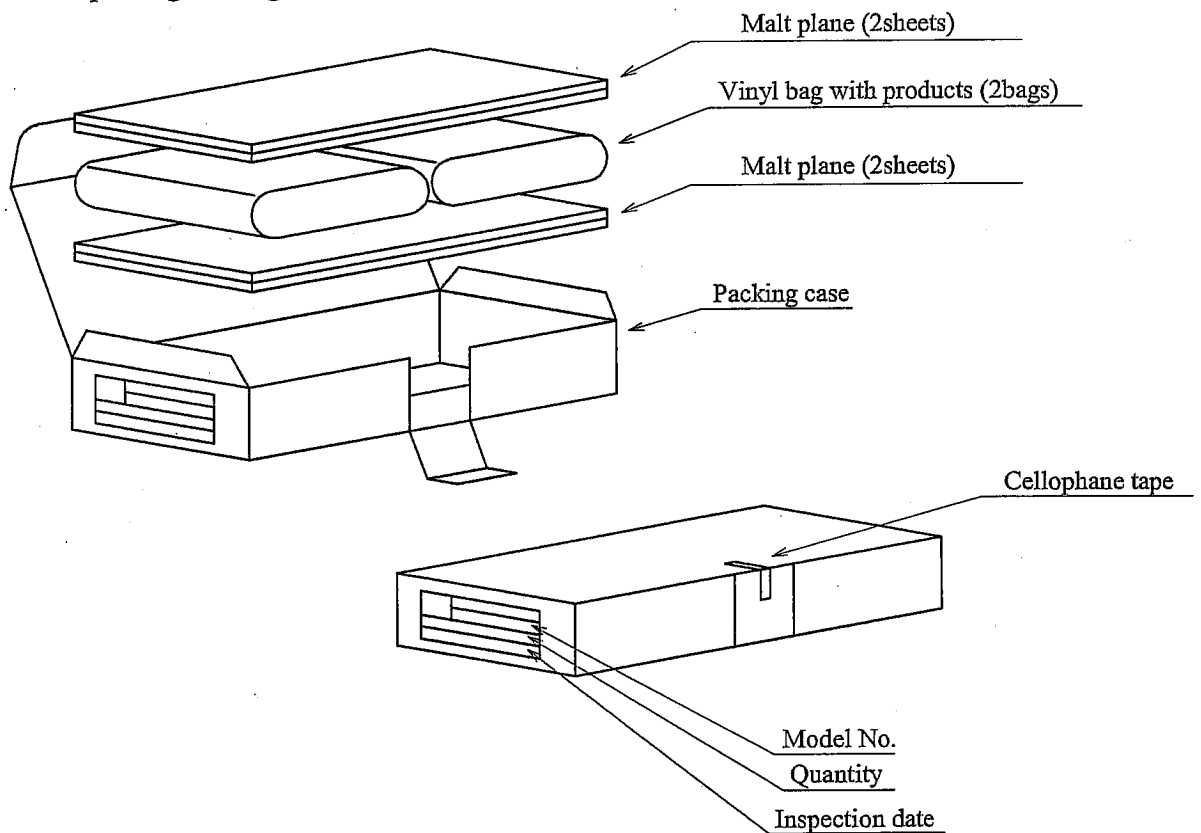

② Outer material : Packing case (Corrugated cardboard),  
Malt plane (Urethane), Cellophane tape

③ Quantity : 2,000pcs./box

④ Indication : Model No., quantity and inspection date

⑤ Regular packaged mass : Approximately 270g