



SPEC. No. ED-08G036
ISSUE July 2, 2008

OPTO-ANALOG DEVICES DIVISION
ELECTRONIC COMPONENTS AND DEVICES GROUP
SHARP CORPORATION

SPECIFICATION

DEVICE SPECIFICATION FOR

MODEL No. PHOTOINTERRUPTER

GP1A058SCK0F

Specified for _____

Enclosed please find copies of the Specifications which consists of 13 pages including cover.
After confirmation of the contents, please be sure to send back copies of the Specifications
with approving signature on each.

CUSTOMER'S APPROVAL

DATE _____

BY _____

PRESENTED

DATE _____

BY Y. Oda

Y. Oda
Department General Manager of
Engineering Dept., III
Opto-Analog Devices Div.
Electronic Components and Devices Group
SHARP CORPORATION

Product name : PHOTOINTERRUPTER

Model No. : GP1A058SCK0F

1. These specification sheets include materials protected under copyright of Sharp Corporation ("Sharp"). Please do not reproduce or cause anyone to reproduce them without Sharp's consent.
2. When using this product, please observe the absolute maximum ratings and the instructions for use outlined in these specification sheets, as well as the precautions mentioned below. Sharp assumes no responsibility for any damage resulting from use of the product which does not comply with the absolute maximum ratings and the instructions included in these specification sheets, and the precautions mentioned below.

(Precautions)

- (1) This product is designed for use in the following application areas ;

(• OA equipment • Audio visual equipment • Home appliances
 • Telecommunication equipment (Terminal) • Measuring equipment
 • Tooling machines • Computers

If the use of the product in the above application areas is for equipment listed in paragraphs (2) or (3), please be sure to observe the precautions given in those respective paragraphs.

- (2) Appropriate measures, such as fail-safe design and redundant design considering the safety design of the overall system and equipment, should be taken to ensure reliability and safety when this product is used for equipment which demands high reliability and safety in function and precision, such as ;

(• Transportation control and safety equipment (aircraft, train, automobile etc.)
 • Traffic signals • Gas leakage sensor breakers • Rescue and security equipment
 • Other safety equipment

- (3) Please do not use this product for equipment which require extremely high reliability and safety in function and precision, such as ;

(• Space equipment • Telecommunication equipment (for trunk lines)
 • Nuclear power control equipment • Medical equipment

- (4) Please contact and consult with a Sharp sales representative if there are any questions regarding interpretation of the above three paragraphs.

3. Please contact and consult with a Sharp sales representative for any questions about this product.

1. Application

This specification applies to the outline and characteristics of transmissive type photointerrupter,
Model No. GP1A058SCK0F.

2. Outline

Refer to the attached drawing No. CY14075i02. Page 4.

3. Ratings and characteristics

- Refer to the attached sheet, Page 5 to 8.
- Resolution : 180LPI (141 μ m)
- Output waveform : Digital 2-phase (Phase A and Phase B)

4. Reliability

Refer to the attached sheet, Page 9.

5. Outgoing inspection

Refer to the attached sheet, Page 10.

6. Supplements

6.1 Parts

Refer to the attached sheet, Page 11.

6.2 Packing

Refer to the attached drawing No. CY14077i09, Page 12.

6.3 ODS materials

This product shall not contain the following materials.

Also, the following materials shall not be used in the production process for this product.

Materials for ODS : CFCs, Halon, Carbon tetrachloride, 1.1.1-Trichloroethane (Methyl chloroform)

6.4 Specified brominated flame retardants

Specified brominated flame retardants (PBB and PBDE) are not used in this device at all.

6.5 Compliance with each regulation

6.5.1 The RoHS directive(2002/95/EC)

This product complies with the RoHS directive(2002/95/EC)

Object substances: mercury,lead, cadmium,hexavalent chromium,polybrominated biphenyls (PBB)
and polybrominated diphenyl ethers (PBDE)

6.5.2 Content of six substances specified in Management Method for Control of Pollution Caused by Electronic Information Products Regulation (Chinese : 电子信息产品污染控制管理办法).

Category	Toxic and hazardous substances					
	Lead (Pb)	Mercury (Hg)	Cadmium (Cd)	Hexavalent chromium (Cr ⁶⁺)	Polybrominated biphenyls (PBB)	Polybrominated diphenyl ethers (PBDE)
Photointerrupter	✓	✓	✓	✓	✓	✓

✓ : indicates that the content of the toxic and hazardous substance in all the homogeneous materials of the part is below the concentration limit requirement as described in SJ/T 11363-2006 standard.

6.6 Product mass : Approximately 0.85g

6.7 Country of origin : Japan, China, Indonesia

7. Notes

7.1 The recommendation conditions of forward current:

This product is designed in consideration of using this product under the condition of typical $I_F=20\text{mA}$ as a standard.

7.2 In order to stabilize power supply line, it is recommended to have a by-pass capacitor of $0.1\mu\text{F}$ or more between Vcc and GND near the device.

7.3 Lens is made from resin, as to cleaning, this photointerrupter should not be cleaned by cleaning materials absolutely. (Dust and stain shall be cleaned by air blow.)

7.4 Soldering

To solder onto lead pins, please solder at 260°C for 5s or less with longer distance than 1.6mm from the bottom surface of the package.

Please take care not to let any external force exert on lead pins when soldering or just after soldering.

Please don't do soldering by reflow.

7.5 OPIC chip due to micro design is easily affected by the Electro static discharge.

At operating, in order to prevent the destruction and the defect of characteristics by Electro static discharge, please take a general countermeasure of the Electro static discharge.

7.6 Prevention of malfunction

For this product, the transparent material is used as the case material .

Before using this product, please confirm the following items with the actual equipment.

1) The product does not malfunction by the ambient light illuminating the photo-detector surface.

2) Other equipment is not affected by the light leaking from the light-emitting device.

7.7 Storage and usage environment

Polycarbonate is used as the case material of this product.

If polycarbonate contacts with the hot liquid and the alkaline solution (alkaline atmosphere), polycarbonate is hydrolyzed. Therefore, please do not store and use this product in such an environment.

7.8 When tightening this product with the screw, please use the M2.6 machine screw.

The recommended tightening torque with M2.6 machine screw is 0.25 to 0.35 N · m.

However, this recommended tightening torque is the reference value because the tightening torque varies according to the screw and the bolted joint .

Before tightening the screw, please certainly confirm the tightening strength of this product

and the object on which this product is mounted. Also, when tightening the screw with the tools such as the screw-driver, if the pushing force by the screw-driver is too strong, the damage of the product performances such as the break of the holder's mounting hole may be caused by the application of the external force.

Therefore, please be careful not to apply such a force to this product.

2. Outline (Drawing No. CY14075i02) Scale : 2/1 Unit : mm

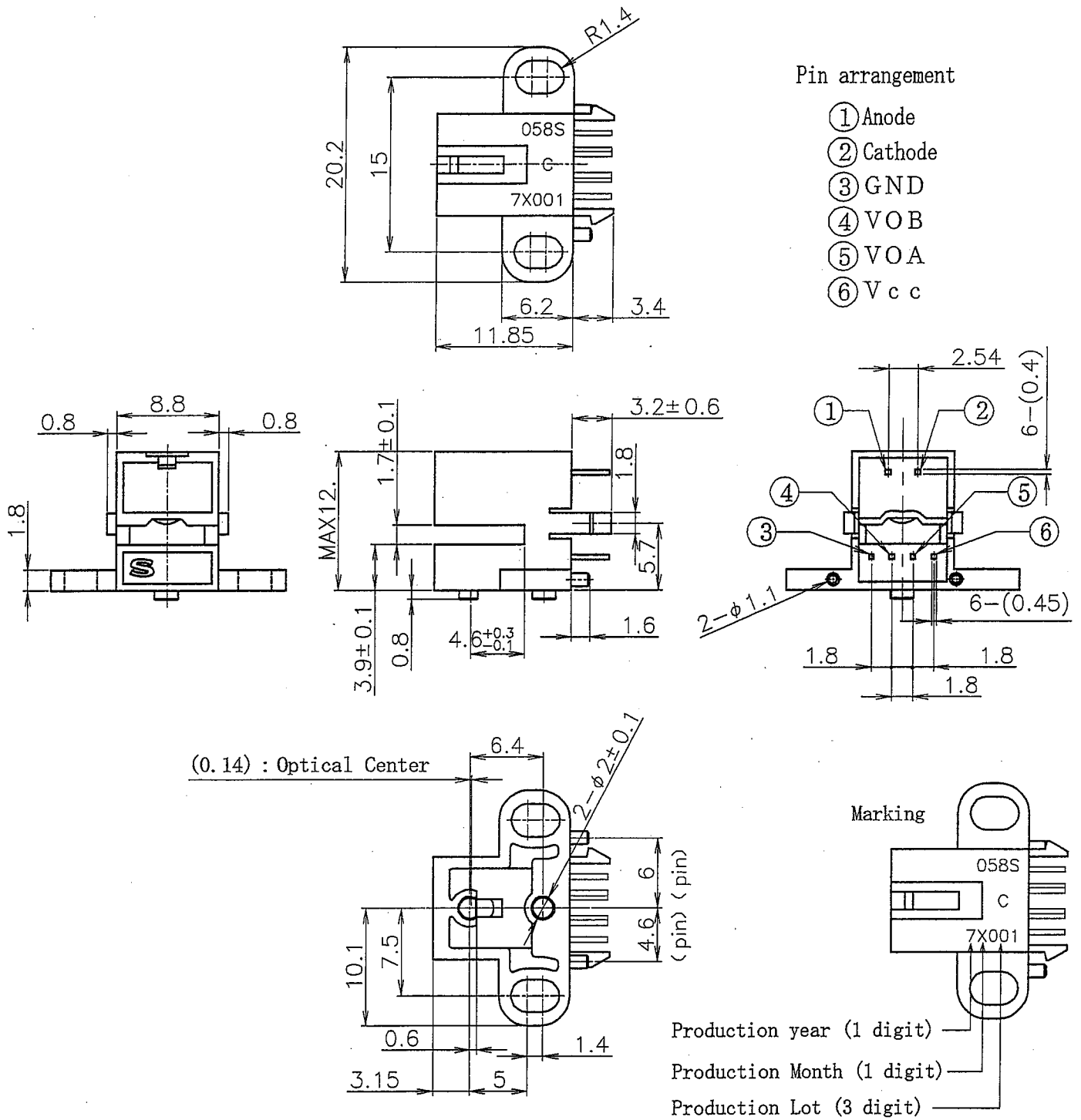

Notes

- 1) Unspecified tolerances shall be ± 0.3 .
- 2) Dimensions in parenthesis are shown for reference.
- 3) The dimensions indicated by * refer to the those measured from the lead base.
- 4) Datecode is 5 digit.
 - (Production year) The last number of the year.
 - (Production Month) From 1 to 9, it mean January to September.
X is October, Y is November and Z is December.
 - (Production Lot) 001 means Production Lot No. "001"

3. Ratings and characteristics

3.1 GP1A058SCK0F block diagram

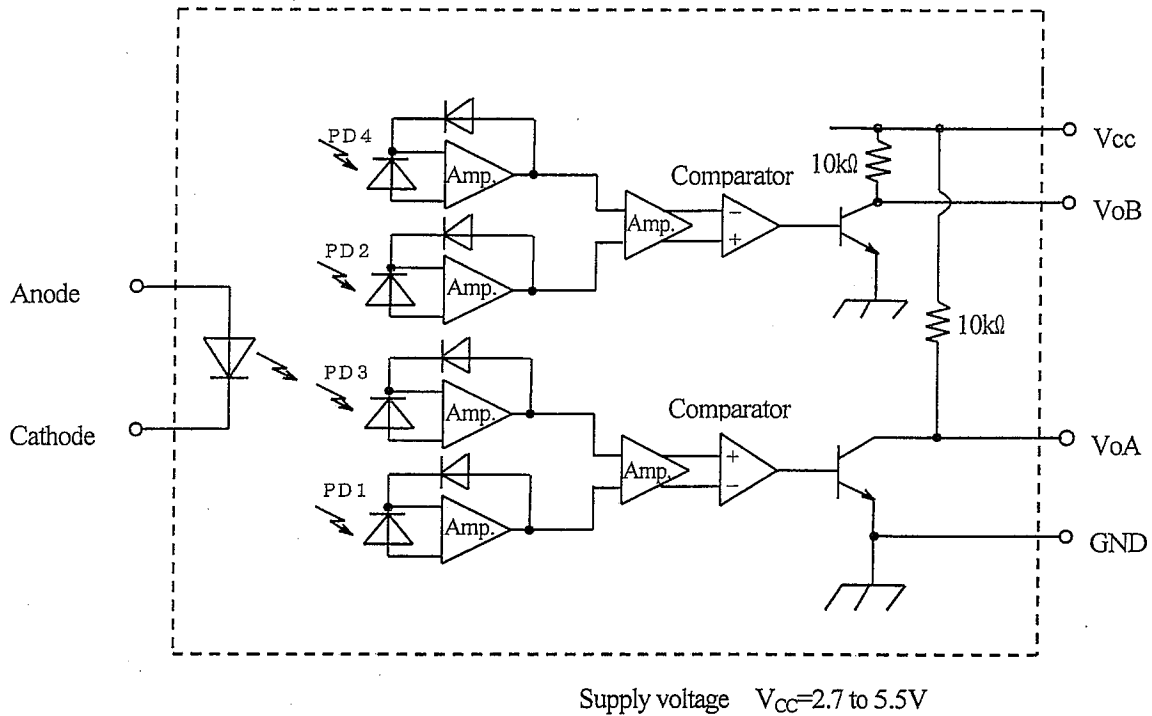

3.2 Absolute maximum ratings

 $T_a=25^\circ\text{C}$

Parameter		Symbol	Rating	Unit
Input	Forward current *1	I_F	30	mA
	Reverse voltage	V_R	4	V
Output	Supply voltage	V_{CC}	6	V
	Low level output current	I_{OL}	8	mA
	Power dissipation *1	P_o	150	mW
Operating temperature		T_{opr}	-10 to +70	$^\circ\text{C}$
Storage temperature		T_{stg}	-40 to +80	$^\circ\text{C}$
Soldering temperature *2		T_{sol}	260	$^\circ\text{C}$

*1 The derating factors of absolute maximum ratings due to ambient temperature are shown in Fig. 1, 2.

*2 Soldering time : 5s or less

3.3 Electro-optical characteristics

Ta=25°C

Parameter		Symbol	Conditions	MIN.	TYP.	MAX.	Unit
Input	Forward voltage	V_F	$I_F=20\text{mA}$	-	2.1	2.6	V
	Reverse current	I_R	$V_R=1\text{V}$	-	-	100	μA
Output	Operating supply voltage range	V_{CC}	-	2.7	3.3	5.5	V
	Low level output voltage	V_{OL}	$V_{CC}=3.3\text{V}, I_F=20\text{mA}$ $I_{OL}=8\text{mA}$	-	-	0.4	V
	High level output voltage	V_{OH}	$V_{CC}=3.3\text{V}, I_F=20\text{mA}$	2.4	3.2	-	V
	Supply current	I_{CC}	$V_{CC}=3.3\text{V}, I_F=20\text{mA}$ Phases A and B both at low level	-	2.2	5.5	mA
Transfer characteristics ※1	Duty	D_A	$V_{CC}=3.3\text{V}$ $I_F=20\text{mA}$ $f=10\text{kHz}$ $0.1\text{mm} < Z \leq 1.0\text{mm}$ ※2	35	50	65	%
		D_B					
	Phase difference	$\theta_{AB1 \text{ to } 4}$		45	90	135	°
	Response	t_r		-	1.0	2.0	μs
		t_f		-	1.0	2.0	
Response frequency	f_{max}	$V_{CC}=3.3\text{V}, I_F=20\text{mA}$ $0.1\text{mm} < Z \leq 1.0\text{mm}$ ※2	-	-	60	kHz	

※1 The test condition is according to Fig.3 (CY14076i06)

And transfer characteristics value does not include any error of code-wheel (Liner scale).

The error of slit-pattern shall not be included.

※2 Z stands for distance between code-wheel (Liner scale) surface (patterned surface) and detector holder surface, and patterned surface shall be arranged face to face with detector holder surface.

The code-wheel (Liner scale) shall not contact with the holder surface.

Note: It is recommended that the GP1A058SCK0F be used under the condition of typical $I_F=20\text{mA}$ for which it is designed.

3.4 Output waveform

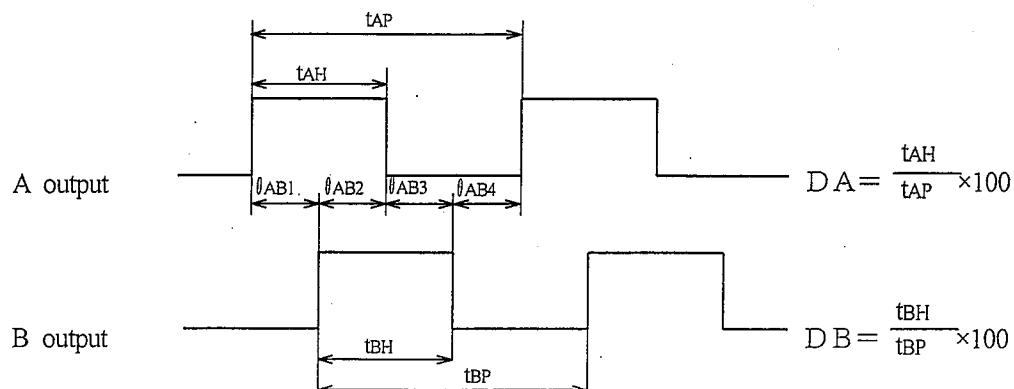

Refer to note 1 in Fig.3 (CY14076i06) for the moving direction of Liner scale (code-wheel).

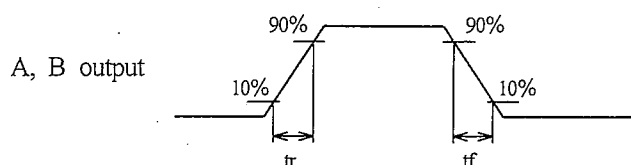

Fig.1 Forward current vs. ambient temperature

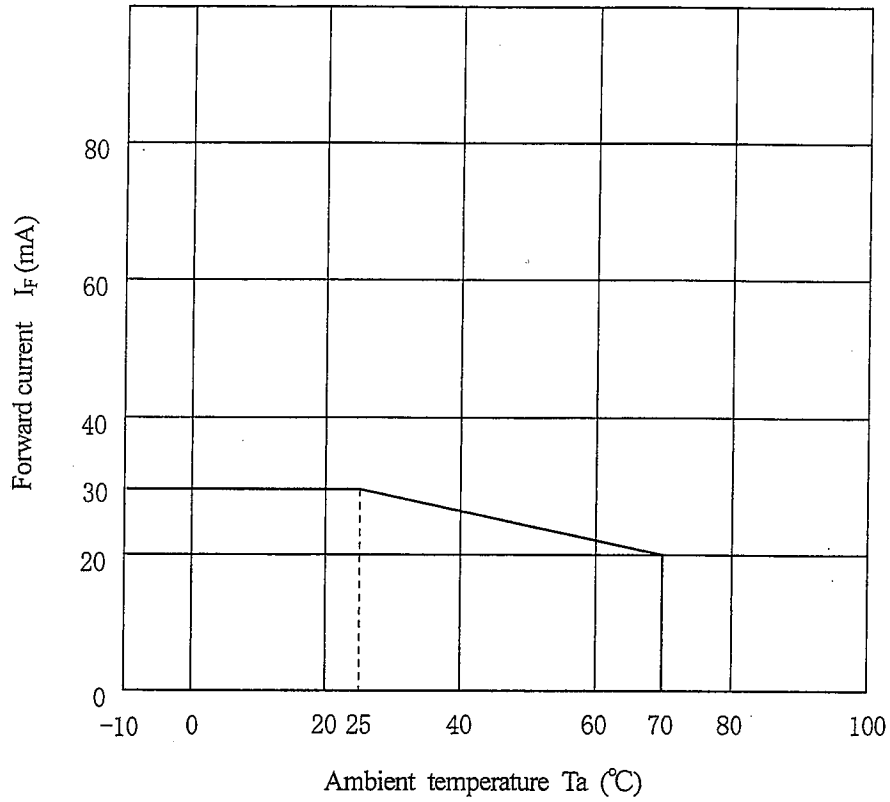
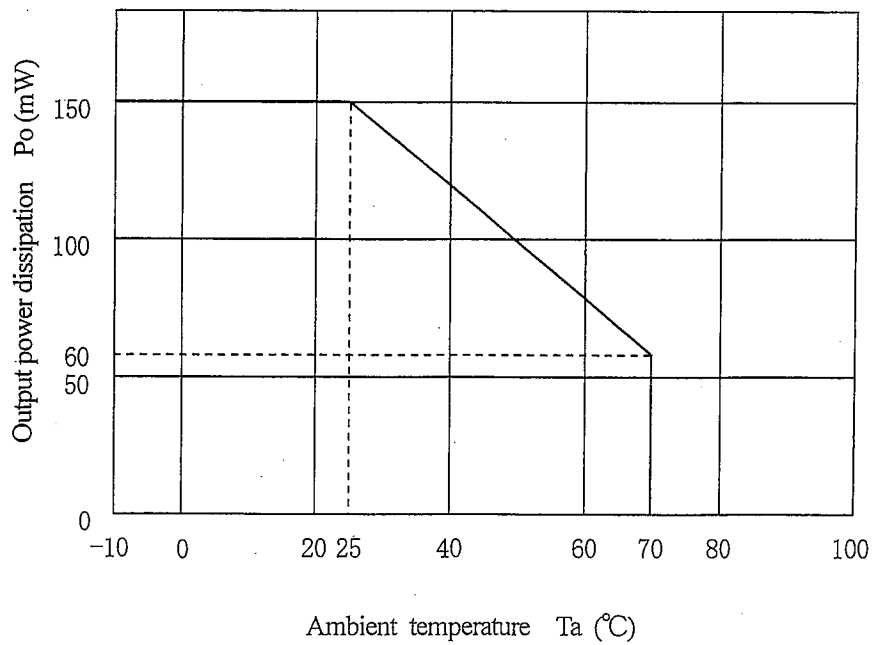

Fig.2 Output power dissipation vs. ambient temperature



GP1A058SCK0F

Fig3 GP1A058SCK0F Test Condition (Drawing No.CY14076i06)

Scale : free Unit : mm

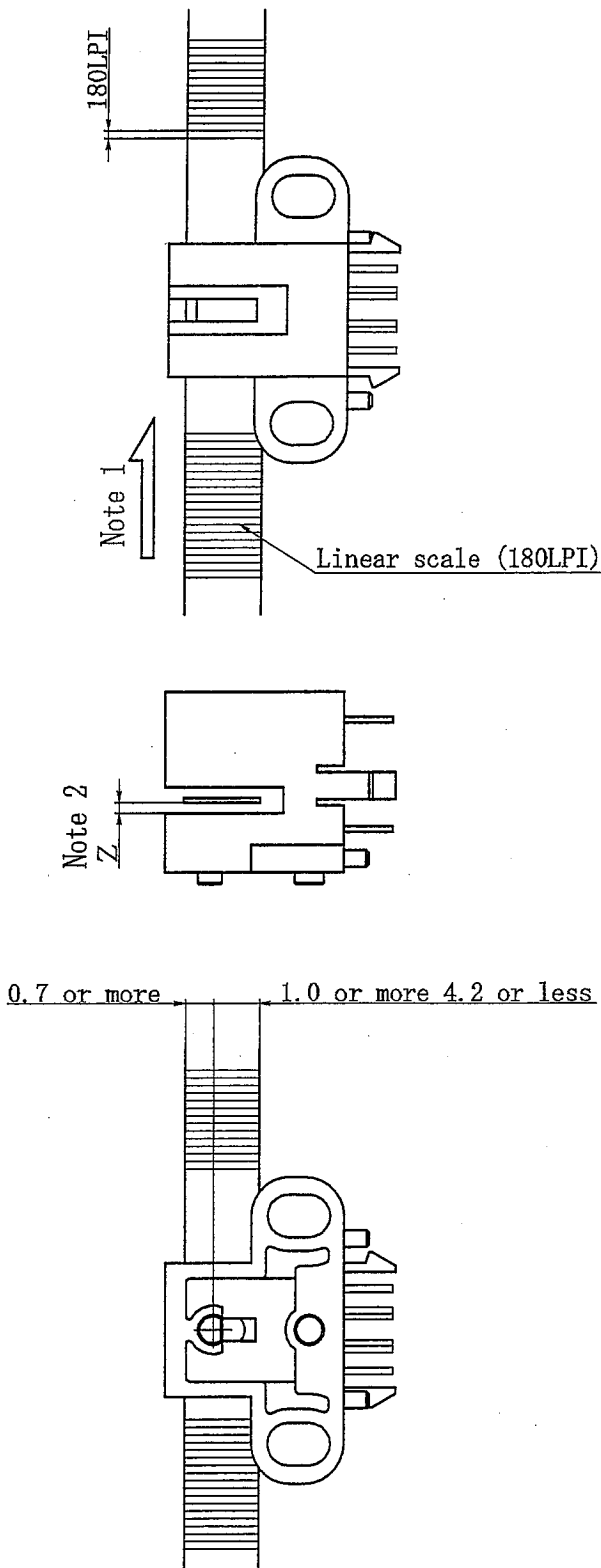

Notes

- 1) The moving direction of Liner scale(code-wheel) against output waveform (Refer to 3.4).
- 2) Z:Distance between Liner scale(code-wheel) surface (patterned surface)and detector holder surface.
 $\ast 0.1\text{mm} < Z \leq 1.0\text{mm}$
 The Liner scale(code-wheel) shall not contact with the holder surface.

4. Reliability

The reliability of products shall satisfy items listed below.

Confidence level : 90%

LTPD : 10 or 20

Test Items	Test Conditions	Failure Judgement Criteria	Samples (n)
			Defective (c)
Temperature cycling	1 cycle -40°C to +80°C (30min) (30min) 20 cycles test	$V_F \geq U \times 1.2$	n=22, c=0
High temp. and high humidity storage	+60°C, 90%RH, 500h	$I_R \geq U \times 2$	n=22, c=0
High temp. storage	+80°C, 500h	$V_{OL} \geq U \times 1.2$	n=22, c=0
Low temp. storage	-40°C, 500h	$V_{OH} \leq L \times 0.8$	n=22, c=0
Operation life	$I_F=20\text{mA}$, $V_{CC}=3.3\text{V}$, $T_a=25^\circ\text{C}$, 500h		n=22, c=0
Mechanical shock	15000m/s ² , 0.5ms 3 times/ $\pm X$, $\pm Y$, $\pm Z$ direction	$I_{CC} \geq U \times 1.2$	n=11, c=0
Variable frequency vibration	100 to 2000 to 100Hz/4min 4 times/ X , Y , Z direction 200m/s ²	Duty : Shall be within the specification values.	n=11, c=0
Terminal strength (Tension)	Weight: 5N 30s/each terminal		n=11, c=0
Terminal strength (Bending)	Weight: 5N 0° →90° →0° →-90° →0° 1time bending	U: Upper specification limit	n=11, c=0
Soldering heat	260°C, 5s Immerse up to 1.6mm from the side face of package.	L: Lower specification limit	n=11, c=0
Solderability	245±3°C, 5s	*1	n=11, c=0

* Test conditions shall be based upon the specification.

*1 Solder shall adhere at less than 95% area of immersed portion of lead.

The alloy composition of solder used for lead free should be Sn-3.0Ag-0.5Cu.

Flux used for precleaning should be equivalent to EC-19S-8(TAMURA KAKEN CORPORATION).

5. Outgoing inspection

5.1 Inspection items

(1) Electrical characteristic

 $V_F, I_R, V_{OL}, V_{OH}, I_{CC}, D_A, D_B, \theta_{AB1 \text{ to } 4}$

(2) Appearance

5.2 Sampling method and Inspection level

A single sampling plan, normal inspection level II based on ISO 2859 is applied.

The AQL according to the inspection items are shown below.

Defect	Inspection item	AQL
Major defect	Electrical characteristics defect (Refer to parameter 3.3) Unreadable marking (Refer to parameter 2)	0.1%
Minor defect	Appearance defect except the above mentioned (Defects that may conflict with product specifications, including crack, split, chip scratch, burr, blur and foreign material.)	0.25%

6. Supplements

6.1 Parts

This product uses the below parts.

6.1.1 Light detector (Quantity : 1)

(Using a silicon photodiode as light detecting portion, and a bipolar IC as signal processing circuit.)

Type	Maximum sensitivity wavelength (nm)	Sensitivity wavelength (nm)	Response time (μ s)
Photodiode	780	400 to 1200	16.7

6.1.2 Light emitter (Quantity : 1)

Type	Material	Maximum light emitting wavelength (nm)
Light emitting diode (Non-coherent)	AlGaInP /GaAs	652

6.1.3 Material

Holder integrated with Lens	Lead flame finish
Transparent polycarbonate resin	Solder dip (Sn-Ag-Cu)

6.1.4 Others

This product shall not be radiation flux proof.

Laser generator is not used.

6.2 Packing (Drawing No. : CY14077i09)

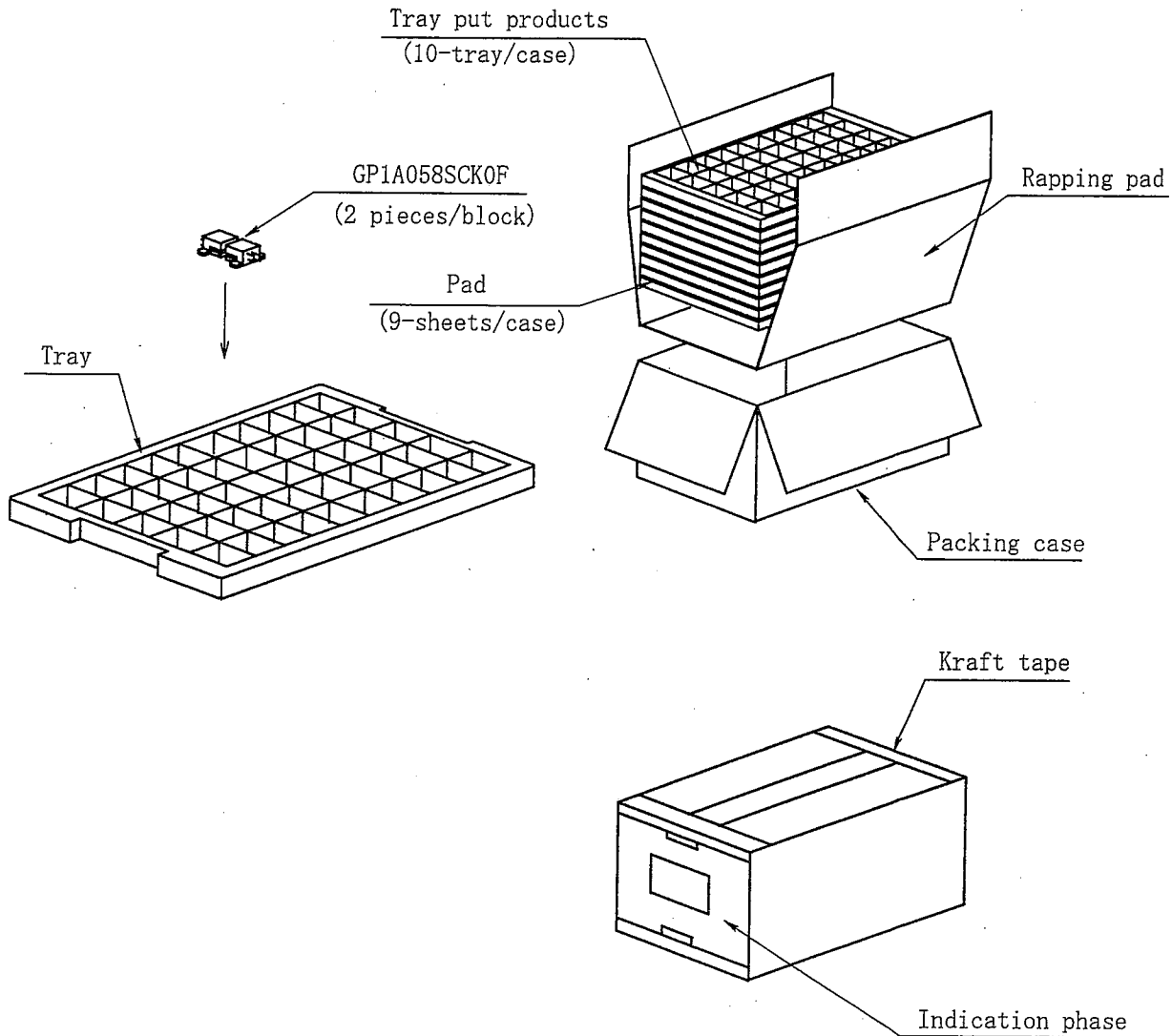

1) Package materials

- Outer package : Outer case (Paper corrugated cardboard)
- Inner package : Pad (Polyethylene)
Rapping pad (Polyethylene)
Tray (Polysthylene)

2) Packaging number

- Max. 100 pieces per tray
- Max. 1000 pieces per case

3) Package specifications

- Put them (10 tray) in the packing box.
- Put pads on their top and bottom, between them.
- Seal the packing box with kraft tape.

4) Indication items

- The contents of the carton indication conforms to EIAJ C-3 and the following items are indicated.
Model No., Internal production control name, Quantity, Packing date, Corporate name, Country of origin.

5) Regular packing mass

- (Excluding fractions, however above packing material, packing count, packing style)
- Approximately 2.3kg