

SHARP

SPEC No. ED-04CH3-A
ISSUE February 24, 2006

REFERENCE

OPTO-ANALOG DEVICES DIVISION
ELECTRONIC COMPONENTS GROUP
SHARP CORPORATION

SPECIFICATION

DEVICE SPECIFICATION FOR

PHOTODIODE

MODEL No.

PD410PI2E00F

Specified for

Enclosed please find copies of the Specifications which consists of 9 pages including cover.
After confirmation of the contents, please be sure to send back copy of the Specifications
with approving signature on each.

CUSTOMER'S APPROVAL

DATE

BY

PRESENTED

DATE

BY

H. O

H. Ogura,
Department General Manager of
Engineering Dept., III
Opto-Analog Devices Div.
ELECOM Group
SHARP CORPORATION

Product name : PHOTODIODE

Model No. : PD410PI2E00F

1. These specification sheets include materials protected under copyright of Sharp Corporation ("Sharp"). Please do not reproduce or cause anyone to reproduce them without Sharp's consent.
2. When using this product, please observe the absolute maximum ratings and the instructions for use outlined in these specification sheets, as well as the precautions mentioned below. Sharp assumes no responsibility for any damage resulting from use of the product which does not comply with the absolute maximum ratings and the instructions included in these specification sheets, and the precautions mentioned below.

(Precautions)

- (1) This product is designed for use in the following application areas ;

{

- OA equipment · Audio visual equipment · Home appliances
- Telecommunication equipment (Terminal) · Measuring equipment
- Tooling machines · Computers

If the use of the product in the above application areas is for equipment listed in paragraphs (2) or (3), please be sure to observe the precautions given in those respective paragraphs.

- (2) Appropriate measures, such as fail-safe design and redundant design considering the safety design of the overall system and equipment, should be taken to ensure reliability and safety when this product is used for equipment which demands high reliability and safety in function and precision, such as ;

{

- Transportation control and safety equipment (aircraft, train, automobile etc.)
- Traffic signals · Gas leakage sensor breakers · Rescue and security equipment
- Other safety equipment

- (3) Please do not use this product for equipment which require extremely high reliability and safety in function and precision, such as ;

{

- Space equipment · Telecommunication equipment (for trunk lines)
- Nuclear power control equipment · Medical equipment

- (4) Please contact and consult with a Sharp sales representative if there are any questions regarding interpretation of the above three paragraphs.

3. Please contact and consult with a Sharp sales representative for any questions about this product.

1. Application

This specification applies to the outline and characteristics of Silicon photodiode Model No. PD410PI2E00F.

2. Outline

Refer to the attached drawing No. CY12796G02.

3. Ratings and characteristics

Refer to the attached sheet, page 4.

4. Reliability

Refer to the attached sheet, page 6.

5. Outgoing inspection

Refer to the attached sheet, page 7.

6. Supplement

(6-1) Refer to the attached sheet, page 8.

(6-2) This product is not designed against electromagnetic and ionized-particle irradiation.

(6-3) This product shall not contain the following materials.

Also, the following materials shall not be used in the production process for this product.

Materials for ODS : CFCs, Halon, Carbon tetrachloride

1,1,1-Trichloroethane (Methyl chloroform)

(6-4) This product does not contain the chemical materials regulated by RoHS.

(6-5) This product does not contain specific brominated flame retardants such as the PBBOs and PBBs .

(6-6) Product mass (Piece) : Approximately 0.13g

7. Notes

(7-1) Cleaning conditions :

Solvent cleaning : Solvent temperature 45°C or less Immersion for 3 min or less

Ultrasonic cleaning : The effect to device by ultrasonic cleaning differs by cleaning bath size, ultrasonic power output, cleaning time, PCB size or device mounting condition etc.
Please test it in actual using condition and confirm that doesn't occur any defect before starting the ultrasonic cleaning.

The cleaning shall be carried out with solvent below.

Solvent : Ethyl alcohol, Methyl alcohol, Isopropyl alcohol

(7-2) Soldering

The lead pins should be soldered according to the absolute maximum ratings.

While or after soldering, the lead pins shall be free from external force.

This device shall not be soldered with preheat or reflow

The lead pins surface(solder dip) of this device is using lead-free solder.

Regarding lead-free solder, by the kind of solder, there are cases that separation between land pattern and solder occurs. So please use this device after confirmation of the solder issue by actual conditions.

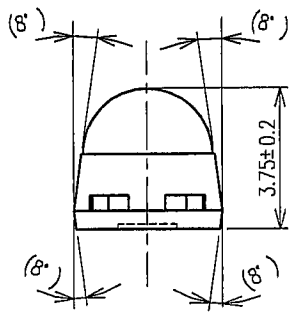
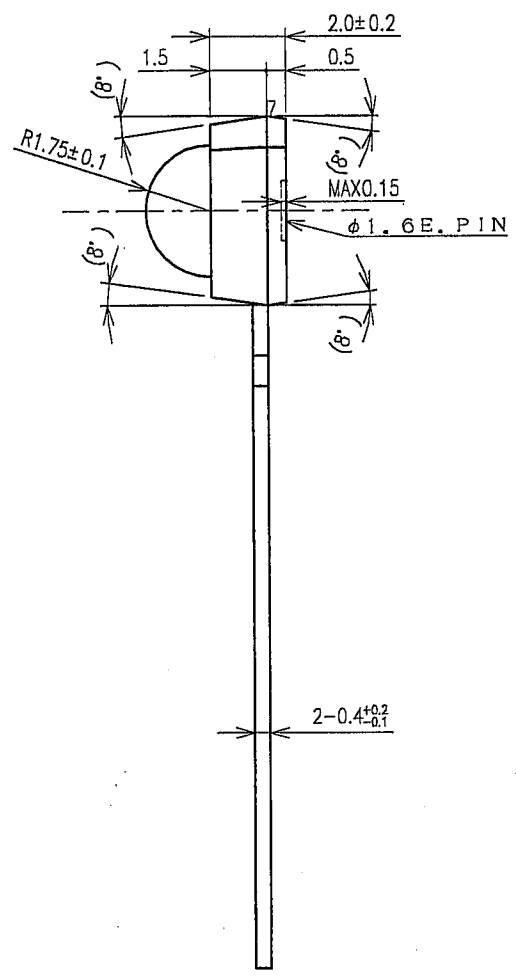
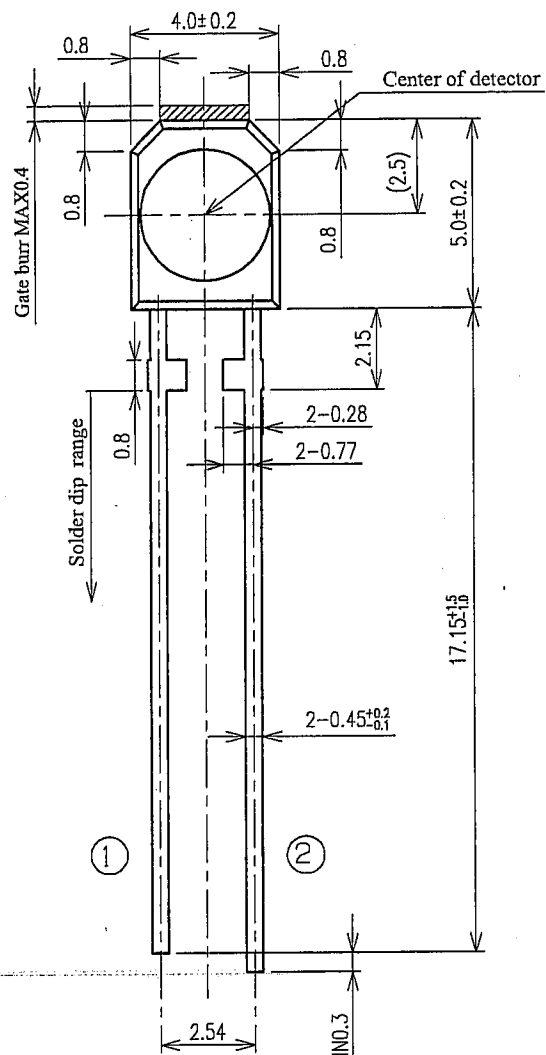

- 1) Unspecified tolerance shall be ± 0.15 .
- 2) Package : Black (Visible light cut-off resin)
- 3) Dimensions in parenthesis are shown for reference.
- 4) The gate burr MAX. 0.4mm shall not be included in the outline dimensions.
- 5) Lead pitch distance refers to the distance at the lead base.

Pin name

Terminal connection

- ① Anode
- ② Cathode

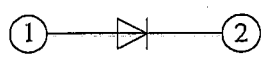

Scale	Material	Finish	Name	PD410PI2E00F	
5 / 1	Lead : Fe Package : Epoxy resin	Lead pin: Solder dip Lead-free solder use Composition(Standard value) Sn96.5%,Ag3.0%,Cu0.5%	Drawing No.	Outline Dimensions	
Unit				C Y 1 2 7 9 6 G 0 2	
1 = 1 / 1 mm					

3. Ratings and characteristics

3.1 Absolute maximum ratings

Ta=25°C

Parameter	Symbol	Rating	Unit
Reverse voltage	V _R	32	V
Power dissipation	P	150	mW
Operating temperature	T _{opr}	-25 to +85	°C
Storage temperature	T _{stg}	-40 to +100	°C
Soldering temperature *	T _{sol}	260	°C

* For 5 seconds MAX. at the position of 2.15mm from the resin edge.

3.2 Electro-optical characteristics

Ta=25°C

Parameter	Symbol	Condition	MIN.	TYP.	MAX.	Unit
Short circuit current	I _{sc}	※ E _v =100 lx	2.5	3.0	4.5	μA
Short circuit current temperature coefficient	β T	※ E _v =100 lx	-	0.2	-	%/°C
Dark current	I _d	V _R =10V, E _v =0	-	0.5	10	nA
Dark current temperature coefficient	α T	V _R =10V, E _v =0	-	3.5	5.0	Times/10°C
Terminal capacitance	C _t	V _R =3V, f=1MHz	-	20	35	pF
Peak sensitivity wavelength	λ _p	-	-	1000	-	nm
Peak spectral sensitivity	K	λ=1000nm	-	1.0	-	A/W
Response time	t _r , t _f	R _L =1kΩ, V _R =10V	-	200	-	ns
Half intensity angle	Δ θ	-	-	±45	-	°

※ E_v: Illuminance by CIE standard light source A (tungsten lamp)

(3.3) Power dissipation vs. ambient temperature

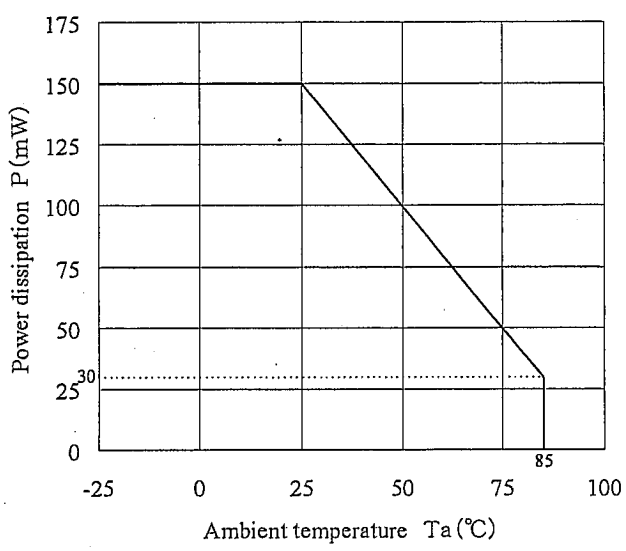

(3.4) Spectral sensitivity (reference)

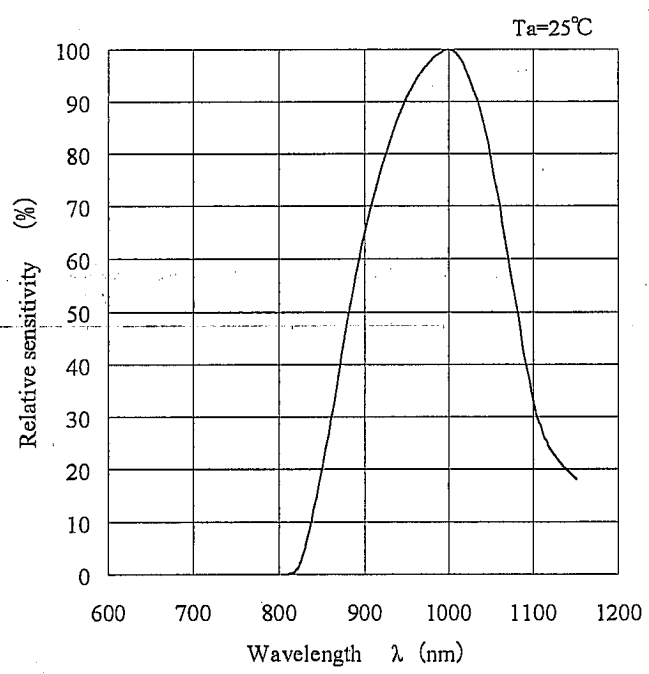

4. Reliability

The reliability of products shall satisfy items listed below.

Confidence level : 90%

LTPD : 10 or 20

Test Items	Test Conditions	Failure Judgement Criteria	Samples (n) Defective(C)
Temperature cycling	1 cycle -40°C ← → +100°C (25min) (25min) 20 cycles test	Isc < L × 0.9 Id > U × 2.0 U: Upper specification limit L: Lower specification limit	n=22, C=0
High temp. and high humidity storage	+60°C, 90%RH, 500h		n=22, C=0
High temp. storage	+100°C, 500h		n=22, C=0
Low temp. storage	-40°C, 500h		n=22, C=0
Operation life	Ev=3000lx, Ta=25°C, 500h		n=22, C=0
High temperature blocking	Ta=+60°C, VR=20V, RL=100kΩ 500h		n=22, C=0
Mechanical shock	1000m/s ² , 6ms, Half sine wave 3 times/±X, ±Y, ±Z direction		n=11, C=0
Variable frequency vibration	100 to 2000 to 100Hz/For approx. 4min 200m/s ² , 48 min/X, Y, Z direction		n=11, C=0
Terminal strength (Tension)	Weight: 5N 10 s/each terminal		n=11, C=0
Terminal strength (Bending)	Weight: 2.5N 0° → 90° → 0° The one test should be performed.		n=11, C=0
Soldering heat	260 ± 5°C, 5 ± 0.5 s Position of 2.15mm from the resin edge.		n=11, C=0
Solderability	245 ± 5°C, 5 ± 1s Position of 2.15mm from the resin edge. Flux: EC-19S (Tamura kaken corporation) No pretreatment	Solder shall adhere at less than 95% area of dipped portion.	n=11, C=0

REFERENCE

5. Outgoing inspection

(1) Inspection lot

Inspection shall be carried out per each delivery lot.

(2) Inspection method

A single sampling plan, normal inspection level II based on ISO2859 shall be adopted.

Parameter	Inspection items and test method				AQL(%)	
Major defect	1	Disconnection, short				0.065
	2	Inverse polarity on terminal				
	3	Characteristics defect				
		Parameter	Symbol	Judgement criteria MIN. MAX.	Unit	
		Short circuit current	Isc	2.5 4.5	μA	
	Dark current	Id	- 10	nA		
	Test conditions refer to parameter 3.2.					
Minor defect	1	Appearance defect				0.25
		Parameter	Judgement criteria			
		Crack	All of crack irrespective of its position and dimension shall be defect.			
	Split, Chip, Scratch, Stain, Blur	One which affects the characteristics of parameter 3.2 shall be defect.				

REFERENCE

6-1 Packaging

6-1-1 Inner packing

① Inner packing drawing

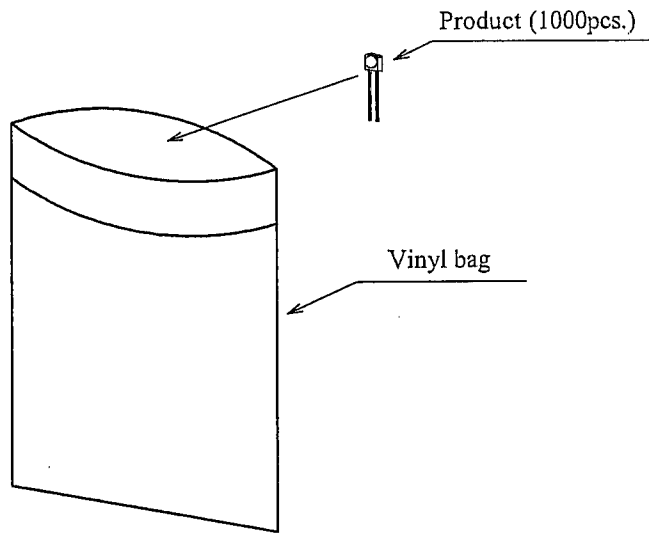

② Inner packing material : Vinyl bag (Polyethylene)

③ Quantity : 1000pcs./bag

6-1-2 Outer packing

① Outer packing drawing

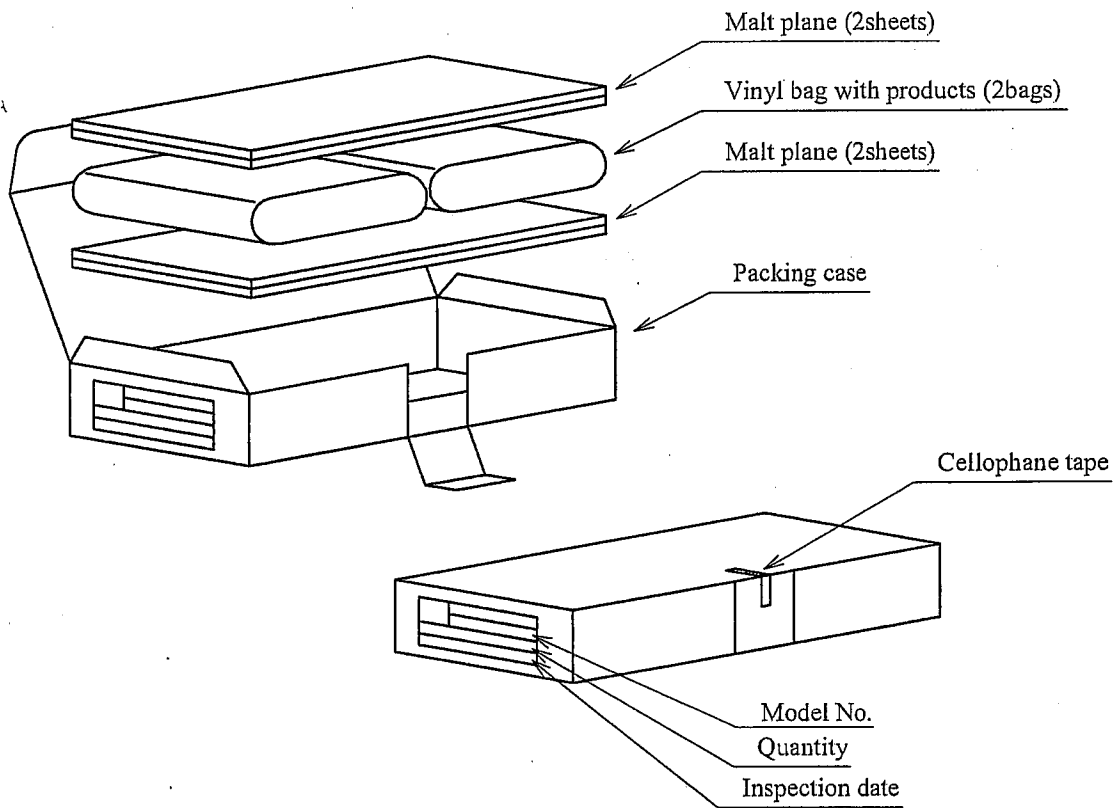

② Outer material : Packing case (Corrugated cardboard),
Malt plane (Urethane), Cellophane tape

③ Quantity : 2000pcs./box

④ Indication : Model No., quantity and inspection date

⑤ Regular packaged mass : Approximately 340g